

Outback Accessories Australia

Part No. XRSGV2 - XROX Steel Tube Bar

Suzuki Grand Vitara JB - All Models 08/2005 – 07/2008



This bar has detachable side wings that can be replaced if damaged; plus 6 spot tabs, 3 aerial tabs, 2 jacking positions, 2 recovery eye and 2 hook locations. (Recovery eyes & hooks are not provided in this kit). The bar has been developed to accept up to a 10,000Lb. Warn low mount winch.

This bar & fitting kit are certified as being compatible with the Air Bag system of this vehicle. The sticker is to be attached to the up side of the centre section of the bumper pressing. The vehicle make and model need to be marked on the sticker with a permanent marker after it has been attached to the bar.

Fitting Instructions

1. Remove the bumper and bumper support brackets from the vehicle. Grill will first need to be removed. Unclip fog lights (if fitted) and sensor wiring. Remove plastic under body splash guards.
2. Remove steel bumper support cross member and discard. Retain 4) 8mm flange nuts for later use.

Bumper Cut:

Use the reference points below to mark a cut line across the bumper. Use masking tape to create a straight line between the points.

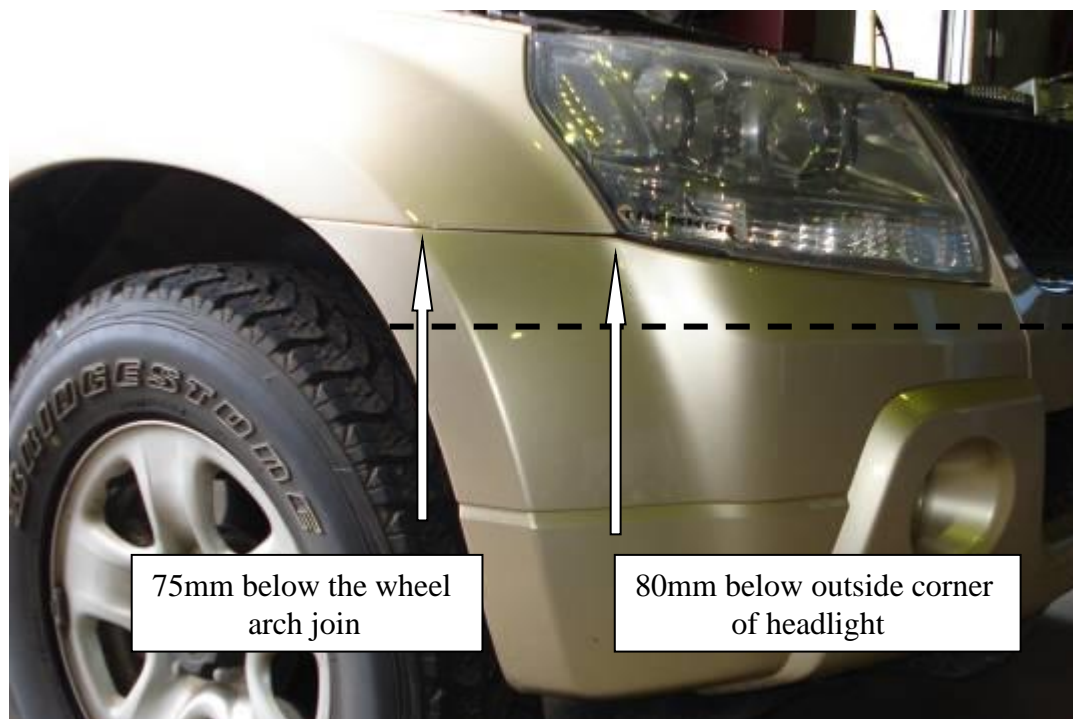
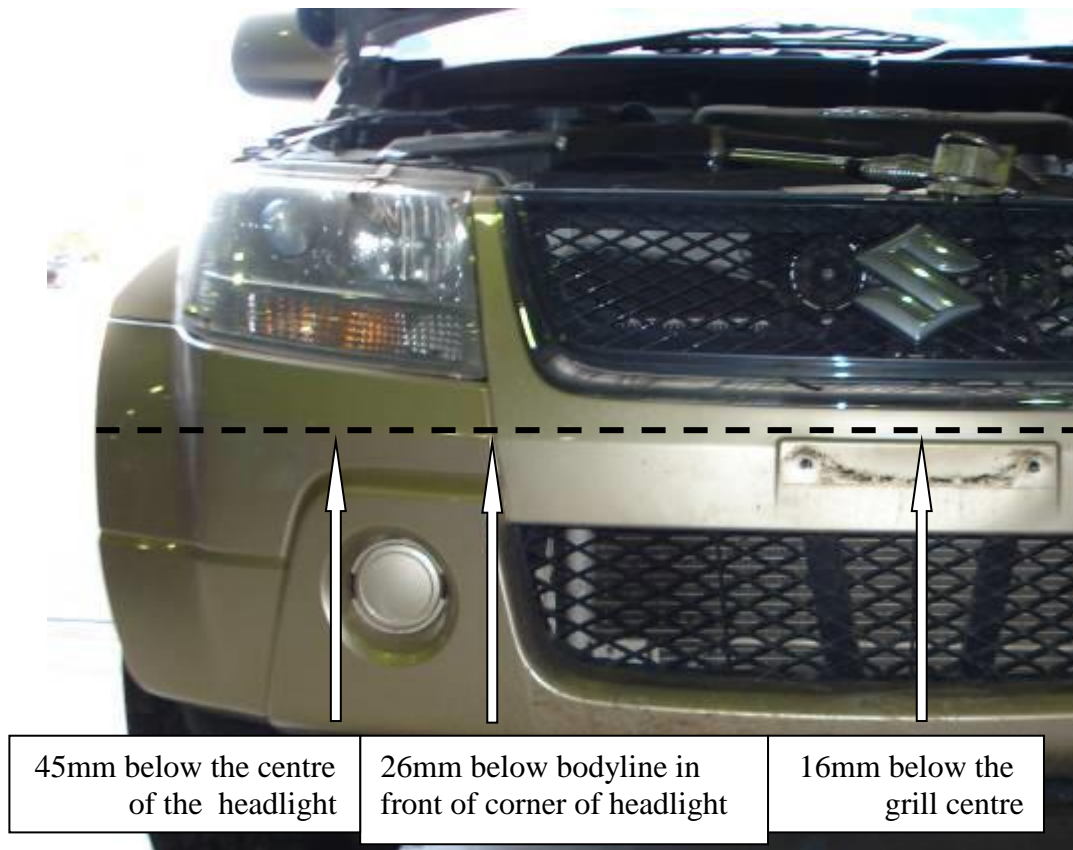

After cutting, clean the cut edge and fit the pinchweld.

Fitting Mounts and Bar:

3. Using a hammer, break tacks and remove the two captive bolts on the chassis closest to the centre of the vehicle (left and right hand side).

4. Loosely fasten the smaller support mount to the inside of the chassis rail with 2) 10x30 bolts, washers, spring washers and 10mm nuts on wire.

5. Once the support mount is fitted, fit the drivers side mount to the chassis and chassis support mount with 2) of the retained flange nuts from step two, 2) M8x25 bolts, nuts, washers and spring washers, 2) M8x40 bolts, nuts, washers and spring washers per side. Drill 2) 10.5mm holes through the side of the chassis through mount holes. Fit 2) M10x30 bolts, washers, spring washers and nuts on wire. Tighten the support mount once the main mount is fitted and tight.

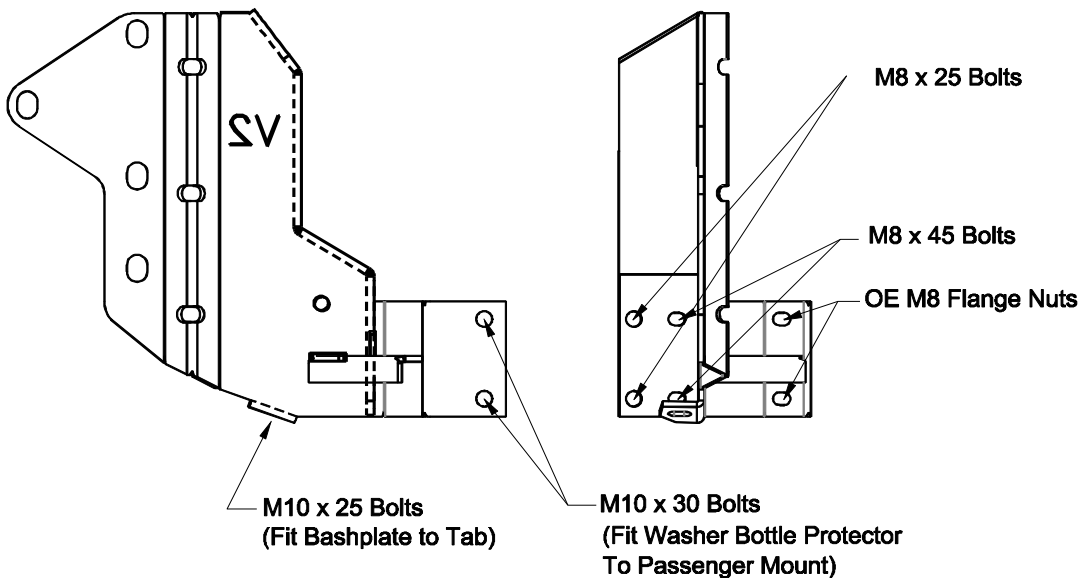
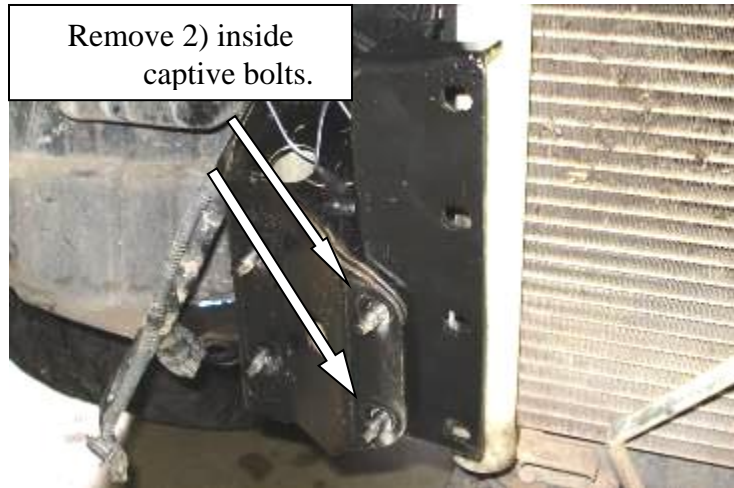

Plan View (Passenger Side)

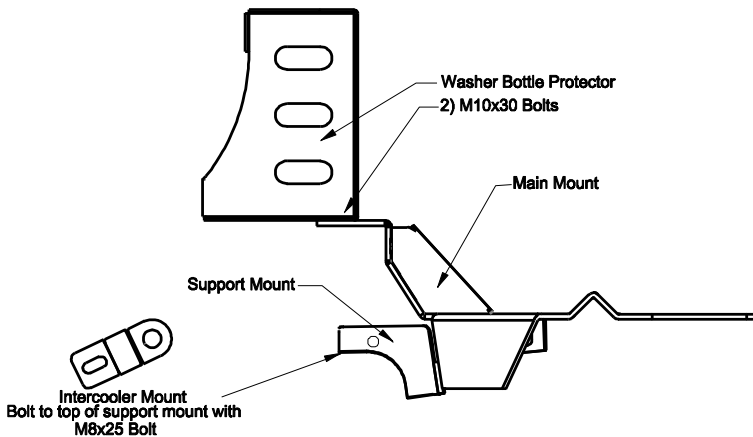

6. Fit the passenger side mount to the chassis following the drivers side instructions up until fitting the 10x30 bolts through the drilled holes in the chassis. The washer bottle guard utilises the 10x30 bolts for fitting. To create enough room to fit the guard, remove 3) bolts holding the washer



bottle in place, then move bottle towards the tyre. 1) screw is located below the bonnet, 1) behind the bumper and 1) behind the mudguard. There is a 4th bolt behind the headlight which can be left in place.

7. Push the washer bottle back into place and fasten once the mount and washer bottle guard has been fitted.
8. Trim the plastic mudguards to suit. Fasten the passenger side mudguard to the washer bottle guard with a 6x20 mudguard washered bolt, nut washer and spring washer.
9. **OPTIONAL front mounted intercooler:** Remove the OE lower rubber mounts from the factory intercooler mounts and insert into the new intercooler mounts. Bolt the mount to the top of the support mount using an M8x25 bolt.
10. **Installing the Xrox centre:** Loosely fit the centre to the mounts using 8) 12x30 bolts, washers, spring washers and nuts.
11. **Installing Xrox wings:** Before tightening the centre, fit the wings using 8) 10x25 bolts, 4) 12x30 bolts, 4) 12x40 button head bolts, nuts, washers and spring washers . Once wings are fitted and tightened, align the bar so it is level and the wings follow the line of the bodywork. Tighten all bolts. Press the tube inserts into the ends of the wings. Use sikaflex or similar sealant to create watertight seal.
12. **Fitting the bashplate:** Loosely fit the centre holes of the bashplate to the vehicle using 2) 6mm mudguard washered bolts. Fit the rear holes using 2) 10mm bolts, washers, spring washers and 10mm nuts welded to 12mm hardened washers. Fit the front holes with 2) 10mm bolts, washers, spring washers and nuts.
13. Fit the number plate using 2) 6mm washered bolts and washered nuts.
14. Check and tighten all bolts.

Kit Contents

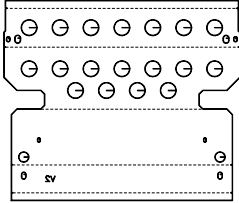
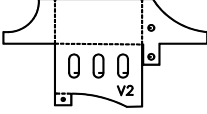
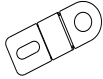
Qty.	Description	Qty.	Description
1	Grand Vitara 2 XROX Centre (C01)	16	12mm Spring Washer
1	Grand Vitara 2 XROX Side Wing R/H (W59)	32	12mm Flat Washers
1	Grand Vitara 2 XROX Side Wing L/H (W60)	14	10x25 Bolts
2	Grand Vitara 2 Mounts: 1 L/H & 1 R/H ID: V2 (XRSGV2-b)	8	10x30 Bolts
2	Grand Vitara 2 Support Mounts: 1 L/H & 1 R/H ID: V2 (XRSGV2-b)	12	10mm Nuts
1	Bashplate ID V2 (XRSGV2-d) 	38	10mm Flat Washers
1	Washer Bottle Guard ID:V2 (XRSGV2-f) 	22	10mm Spring Washers
2	Intercooler Mount Bracket (XRSGV2-a) 	6	8x25 Bolts
2.2M	Pinchweld (No Rubber)	4	8x40 Bolts
2	Plastic Tube Insert (ID 42mm)	10	8mm Nuts
2	Plastic Tube Insert (ID 36mm)	20	8mm Washers
1	Air Bag Protection Sticker	10	8mm Spring Washers
8	10mm Nuts and Washers on 200mm Wire Welded (XRSGV2-h) (Mounts)	2	6x16 Washered Bolts
2	10mm Nuts and 12mm Hardened Washers on 200mm Wire Welded (XRSGV2-h) (Bash Plate)	3	6mm Mudguard Washered Bolts
4	12x40mm button head allan bolts	3	6mm Washered Nuts
12	12x30mm Bolts		
16	12mm Nuts	1	Fitting instructions

Kit Packed by:	Checked By:	Date:
----------------	-------------	-------