

### Mitsubishi Pajero NS-NX 01/2008 On



This bar & fitting kit is certified as being compatible with the Air Bag system of this vehicle. The sticker is to be attached to the top of the centre bumper section. The vehicle make and model need to be marked on the sticker with a permanent marker after it has been attached to the bar.

This bar has detachable side wings that can be replaced if damaged; plus 6 spot tabs, 3 aerial tabs, 2 jacking positions, 2 recovery eyes and 2 hook locations. (Recovery eyes & hooks are not provided in this kit). The bar has been developed to accept a 9,500Lb. Warn low mount winch.

Note: This bar is compatible with the **SGPAJ-1** sump guard.

Note: This bar is not compatible with front sensors or headlight washers where fitted, the systems will need to be disconnected.

#### Fitting Instructions

1. Remove the front grille, bashplate and then the bumper – leaving the flares attached to the vehicle. If the vehicle is fitted with fog lamps, unplug them before removing the bumper. Once the plastic bumper is removed, remove the steel bumper support.
2. To distinguish between left and right mounts the kink in the mount is designed to face inwards – see diagram below. Loosely fit the mounts to the front of the chassis rails where the OE crush cans are located by attaching the mount support



brackets to the mounts using the 10x30 bolts, flat washers, spring washers and nuts. When these are finger tight and clamping the crush can flanges between the mounts and mount supports use a clamp to pull the mount supports hard onto the chassis rail (see figure above) and drill from each side the 4) 12.5mm holes. Fasten the support mounts to the chassis loosely using the 12x120mm bolts, flat washers, spring washers and nuts.

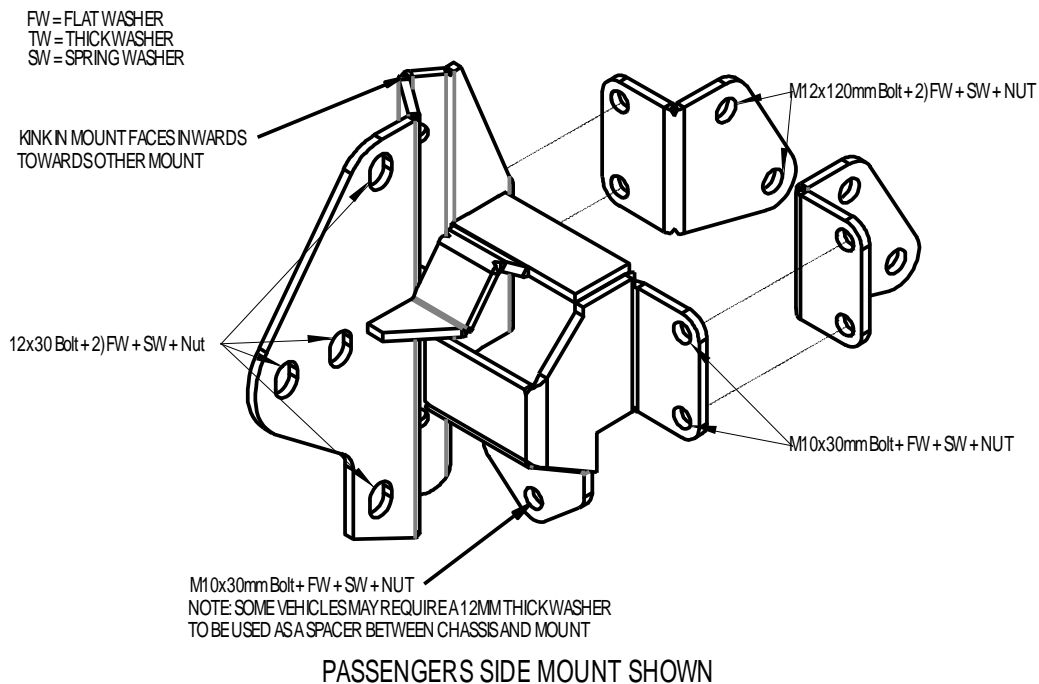

3. Assemble the side tube wings to the bar centre. 6) 10x25 bolts, flat washers, s/washers, nuts and 2) 12x40 button head allen bolts, flat washers, s/washers, nuts **per side** are used to bolt the wing to the centre. Press the tube inserts into the ends of the wings. Use sikaflex or similar sealant to create watertight seal.
4. While the mounts are still loose, loosely attach the bar between the mounts using 4) 12x30mm bolts, flat washers, spring washers and nuts per side. Be careful that the flares do not mark the wing tubes when installing the bar.
5. Tighten the mounts to the chassis, once mounts are tight drill a 10.5mm hole for the bottom forward mounting hole into the chassis. Fasten using a 10x40mm bolt, flat washer, mudguard washer, spring washer and nut. The mudguard washer goes on the inside of the chassis, use a 12mm thick washer as a spacer between chassis and mount if required. **DO NOT OVERTIGHTEN THE 2) 12x120 BOLTS** – This could deform the chassis rails.
6. **Bumper Cut:**

Level and align the bar, cut the flares so that they sit 10mm above the side tubes. Take measurements for the bumper cut and transfer these to the bumper. The bumper cut should run horizontally from the flare cut to approximately 40mm below the lower outer corner of the headlight. From this corner turn the cut upwards into the headlight on a 45° angle. Add a radius between the horizontal and the 45° line to accommodate the pinch weld.



7. Reinstall the cut bumper and check for fitment. Be careful to not scratch the bar with the plastic bumper section.
8. Remove the bar and install the pinchweld. Run the pinchweld so that it joins/ holds the flare to the bumper cut. Install the bar and tighten all bolts.
9. Trim the mudguards to suit the line of the body.
10. Fit the number plate with existing screws.

### Kit Contents

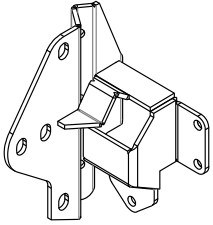
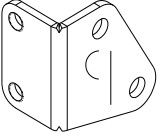
Qty.	Description	Qty.	Description
1	XROX Bar Centre ( <b>C02</b> )	2	12mm Thick Washers
1	XROX Bar Side Wing R/H ( <b>W57</b> )	16	12mm Spring Washer
1	XROX Bar Side Wing L/H ( <b>W58</b> )	16	12mm Nuts
2	Bar Mounts (XRPAJ2-01) 1x L/H & 1x R/H  ID: PJ	2	10x40mm Bolts
4	Mount Supports (XRPAJ-05) <u>2x L/H &amp; 2x R/H</u>  ID:P	8	10x30mm Bolts
4	Plastic Tube Insert 48mm (ID 42mm)	12	10x25mm Bolts
1000mm	Pinch weld 056 – no sponge	22	10mm Spring Washers
1	Air Bag Protection Sticker	42	10mm Flat Washers
4	12x120mm Bolts	2	10mm Mudguard Washers
4	12x40mm Button Head Allan Bolts	22	10mm Nuts
8	12x30mm Bolts		
32	12mm Flat Washers	1	Fitting instructions
Kit Packed by:		Checked By:	
		Date:	