

Nissan Navara D40 STX/STX550 May 2010 on Spanish Build

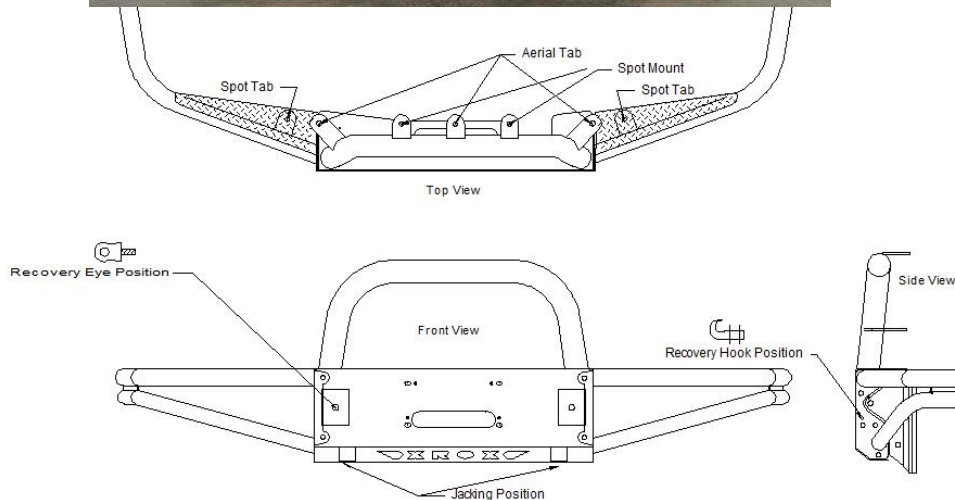

This bar has detachable side wings that can be replaced if damaged; plus 6 spot tab, 3 aerial tabs, 2 jacking positions, 2 recovery eye and 2 hook locations. (Recovery eyes & hooks are not provided in this kit). The bar has been developed to accept up to a 15,000Lb. Warn low mount winch.

Note: This bar was developed for the Spanish built Navara D40 STX and STX550 from May 2010 on. The mounts fit both non-turbo and turbo models.

This bar & fitting kit are certified as being compatible with the Air Bag system of this vehicle. The sticker is to be attached to the up side of the centre section of the bumper pressing. The vehicle make and model need to be marked on the sticker with a ballpoint pen after it has been attached to the bar.

Fitting Instructions

1. Mark a reference line on the bumper 50mm below the centre of the front grill. Use this point to mark a level line around rest of the bumper. Use masking tape above the line to prevent marking the bumper section that will remain.
2. Cut and remove the lower section of the bumper. (A Jig saw can be used for this job).
3. Remove the steel section that is bolted across the front of the chassis and the hook if fitted on the under side of the L/H side of the chassis.

- Fit mounts to both chassis rails using the OE nuts and the 12x30 1.25 thread bolts supplied. Once mounts are level and bolts have been tightened, a 10mm hole will need to be drilled through the chassis rail using the existing holes as a template. A right-angle drill or extended drill bits will be required. Fit the 10x150 bolts and nuts through the mounts and drilled holes. Check all bolts and tighten.



- Press the tube inserts into the ends of the wings. Use sikaflex or similar sealant to create watertight seal, and assemble the side tube wings to the bar centre. 4) M10 bolts, flat washers, s/washers, nuts, 2) M12 button head allan bolts **per side** are used to bolt the front of the side wing to the centre.

- Clean the cut edge of the OE bumper and fit the pinchweld rubber.

- Fit the assembled tube bar to the mounts and align the bar to the vehicle. 4) M12 bolts, flat washers, s/washers and nuts **per side**. Tighten all bolts.



- Fit the Guard to the mounts and chassis using 2) 10x25 Bolts and 2) 8x30 Bolts. Drilling holes in the OE guard will be required.

- Fit the number plate with the existing screws.

This XROX® tube bar comprises of both **powder coated** and **painted** parts, the side sections and centre are powder coated while the mounts are painted with a zinc enriched satin black enamel. If at any stage through the product's life the painted sections show signs of rusting, remove the rust and recoat with satin black zinc enriched enamel.

Kit Contents

Qty.	Description	Qty.	Description
1	Navara XROX Centre (C01)	32	12mm Flat Washers
1	Navara XROX Side Wing R/H (W45)	6	12mm thick Flat Washers
1	Navara XROX Side Wing L/H (W46)	10	10x25mm Bolts
2	NAV3 Mounts 1 L/H & 1 R/H (XRNAV3-1)	2	10x150 Bolts
1	Air Bag Protection Sticker	12	10mm Nuts
4	Plastic Tube Insert 48mm (ID 42mm)	12	10mm Spring Washers
1	Sump Guard Mount (XRNAV3-4)	20	10mm Flat Washers
2400mm	Pinchweld No Rubber	4	10mm Thick Flat Washers
4	12x40mm button head allan bolts	2	8x30 Bolts
12	12x30mm Bolts	2	8mm Nuts
6	12x30mm 1.25 thread Bolts	2	8mm Spring Washers
16	12mm Nuts	4	8mm Flat Washers
22	12mm Spring Washer	1	Fitting instructions

Kit Packed by:	Checked By:	Date:
----------------	-------------	-------