

Mitsubishi Delica L400 Spacegear Series 2 05/1997 - 03/2007



This bar is compatible with the Air Bag system of this vehicle. The compliance sticker must be attached to the topside of the centre section of the bar. The vehicle make and model need to be marked on the sticker with a permanent marker.

Note: This bar does not accommodate the front parking sensors.

This bar has detachable side wings that can be replaced if damaged; plus 6 spot tabs, 3 aerial tabs, 2 jacking positions, 2 recovery eye and 2 hook locations. (Recovery eyes & hooks are not provided in this kit). The bar has been developed to accept up to a 9,500lb. low mount winch.

Fitting Instructions

1. Bumper Removal

- 1.1. Remove the plastic clips and screws connecting the bumper to the inner guards.
- 1.2. Remove the Bumper. There are 2) M6 bolts between the headlights above the radiator fans, 1) short and 1) Long (120mm) M8 per side next to the fog light mounting bracket.
- 1.3. Once bumper has been removed, remove the lower centre bumper support bracket – 4) M6 bolts.

2. Body Trim

Trim the body under the driver's side park light to make it the same as the passenger's side.



3. Mount Installation

- 3.1. Optional: Before fitting mounts spray paint the area that was behind the OE bumper black as this will now be seen with the Xrox® bull bar.
- 3.2. Loosely fit mount 'A', mount support bracket 'B' and mount spacer 'C' onto the front driver's side of the chassis. Repeat for passenger's side mount. To fit mount 'A' on the passenger's side unbolt the 3) M8 bolts that retain the cooler and manoeuvre it up out of the way so that the rear most bolt can be installed under it. When reinstalling the cooler install the cooler guard at the same time. The cooler guard uses 2) M8x25 bolts + FW + SW to replace the 2) M8 bolts that attach to the radiator side and 2) M8x25 bolts + FW + SW + Nuts to attach the guard to the cooler on the opposite side.

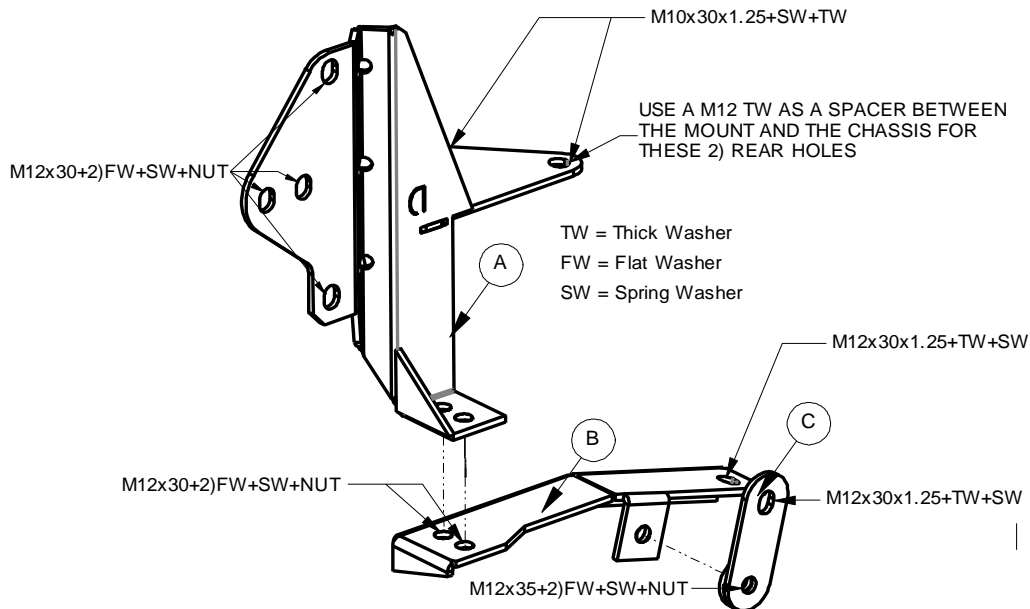

4. Bar Installation

- 4.1. Assemble the side tube wings to the XROX® centre. 6) M10x30 bolts, flat washers, s/washers and nuts, 2) M12x40 button head allan bolts, flat washers, s/washer and nuts **per side** are used to bolt the wings to the centre. Press the tube inserts into the ends of the wings. Use sikaflex or similar sealant to create watertight seal.
- 4.2. Fit the assembled tube bar to the mounts and align the bar to the vehicle. 4) M12x30 bolts, f/washers, s/washers and nuts **per side**. Align and level the bar, tighten all bolts.
- 4.3. Fit the bash plate to the bottom of the mounts using the 2) 12x30 bolts. Use 4) M6x20 mudguard washered bolts to fasten the rear of the bash plate to the lower radiator support rail.
- 4.4. Fit the number plate with existing bolts.





5. Trim Mudguards

- 5.1. Unbolt the driver's side horn and mount the mudguard bracket supplied using an M8x20 bolt + SW + FW. Level bracket and tighten. Do this for each side.
- 5.2. Cable tie and bolt the inner guards to the bracket using 2) long Cable ties and an M8x20 + 2)FW + SW + Nut.
- 5.3. Trim the mudguards starting from the top outer behind the tube wing down to the outer end of the bracket then turn and trim 20mm below the bracket until the point where the bracket bends 45° away from the guard then angle downwards to the lowest mounting point between the inner guard and chassis rail.

6. Install Electrics

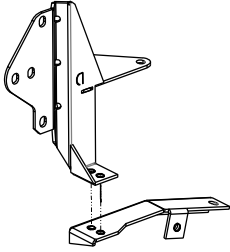
- 6.1. Fasten indicators and park lights to the Xrox wings using 8) M5x10 bolts placing the amber LED lamps to the outside. To fit bolts into indicators and park lights, lever the lenses from the black casing with a small flat head screw driver. NOTE: Do not use an M5 washer on the inside of the LED bracket. Connect indicators and park lights to existing wiring, extending wires where required and test.
- 6.2. OPTIONAL: Install the 2) OE white driving lamps onto spotlight tabs on wings.

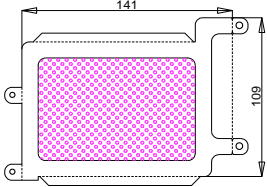
Kit Contents

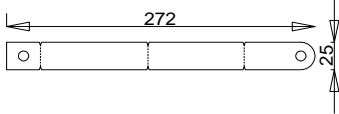
Qty.	Description	Qty.	Description
1	XROX® Bar Centre (C02)	18	12mm Nut
1	XROX® Bar Side Wing R/H (W69)	12	10x25mm Bolt
1	XROX® Bar Side Wing L/H (W70)	4	10x30x1.25 Fine Bolt
2	Bar Mounts (2 piece mount) (XRMD-06) L/H & R/H  ID: D	2	10mm Thick Washer
2	Mount Spacer 'C' - Welded (XRMD-06) 	24	10mm Flat Washer
1	Oil Cooler Guard (XRMD-05) 	16	10mm Spring Washer
1	Front Bash Plate (XRMD-04) ID: D 	12	10mm Nut
2	Mudguard Bracket (XRMD-04) 	4	8x25mm Bolt
1	ADR Compliance Sticker	4	8x20mm Bolt
4	Plastic Tube Insert 48mm (ID 42mm)	12	8mm Flat Washer
2	LED small Amber Indicator Markers	8	8mm Spring Washer
2	LED small Clear Indicator Markers	4	8mm Nut
4	12x40mm Button Head Allen Bolt	4	6x20mm Mudguard Washered Bolt
12	12x30mm Bolt	8	5x10mm Bolts
2	12x35mm Bolt	8	5mm Flat Washer
2	12x30x1.25 Fine Bolt	8	5mm Spring Washer
36	12mm Flat Washer	8	5mm Nuts
6	12mm Thick Washer	4	Long Cable tie
20	12mm Spring Washer	1	Fitting instructions

Kit Packed by:	Checked By:	Date:
----------------	-------------	-------

This XROX® tube bar comprises both **powder coated** and **painted** parts, the side sections and centre are powder coated while the mounts are painted with a zinc enriched satin black enamel. If at any stage through the products life the painted sections show signs of rusting, remove the rust and recoat with satin black zinc enriched enamel.