

Outback Accessories Australia

Part No. XRFR - XROX Steel Tube Bar

Ford Ranger – PJ/PK 12/2006 – 10/2011

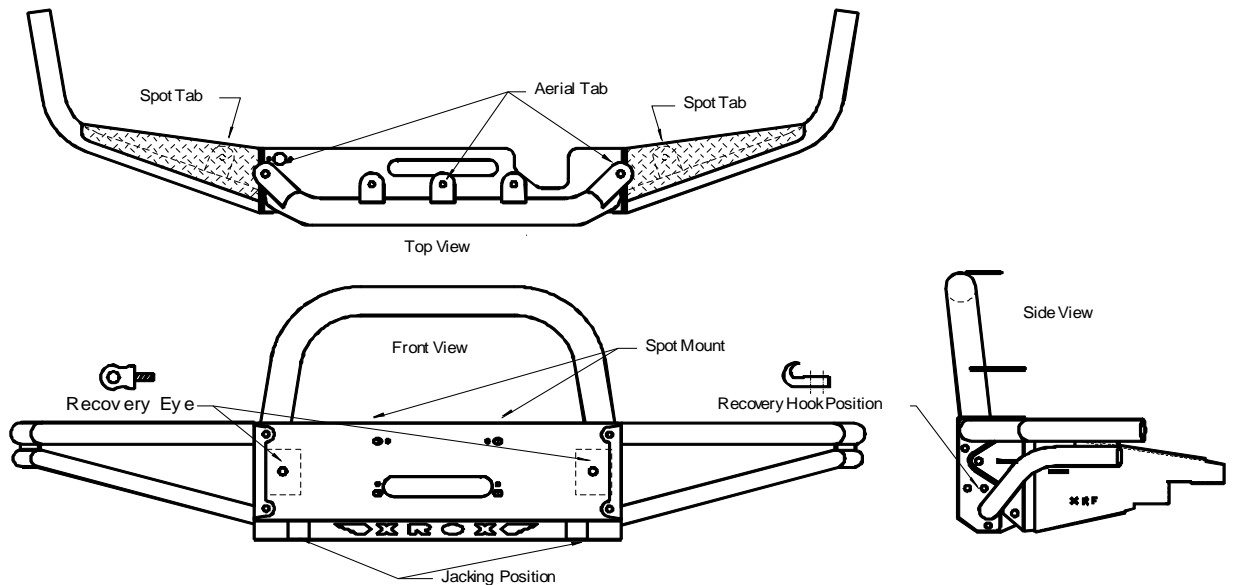

This bar has detachable side wings that can be replaced if damaged; plus 6 spot tab, 3 aerial tabs, 2 jacking positions, 2 recovery eye and 2 hook locations. (Recovery eyes & hooks are not provided in this kit). The bar has been developed to accept up to a 15,000Lb. Warn low mount winch.

Fitting Instructions

PJ Ranger Bumpercut (For PK ranger bumpercut go to instruction #5)

1. Remove bumper and steel bumper support from vehicle.
2. Remove the flare sections from the bumper.
3. Use masking tape to mark a horizontal cut line 25mm below the edge shown in the diagram. Bring the cut line right around to where the bottom of the front grill meets the bumper.

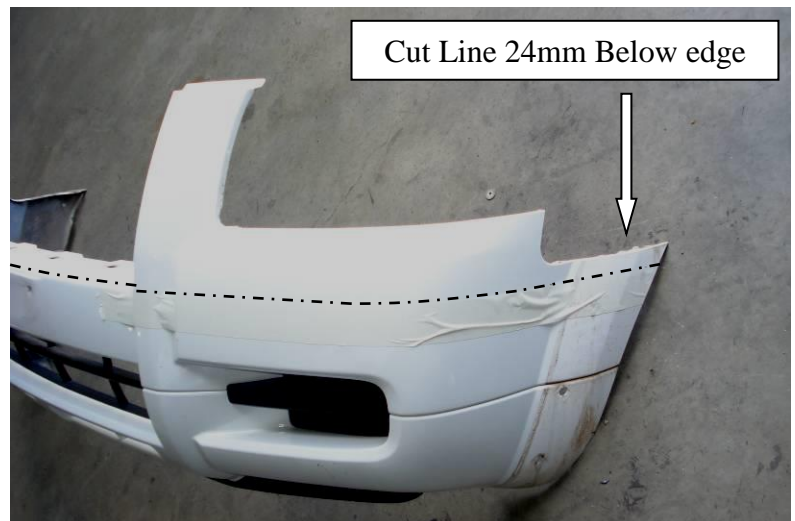

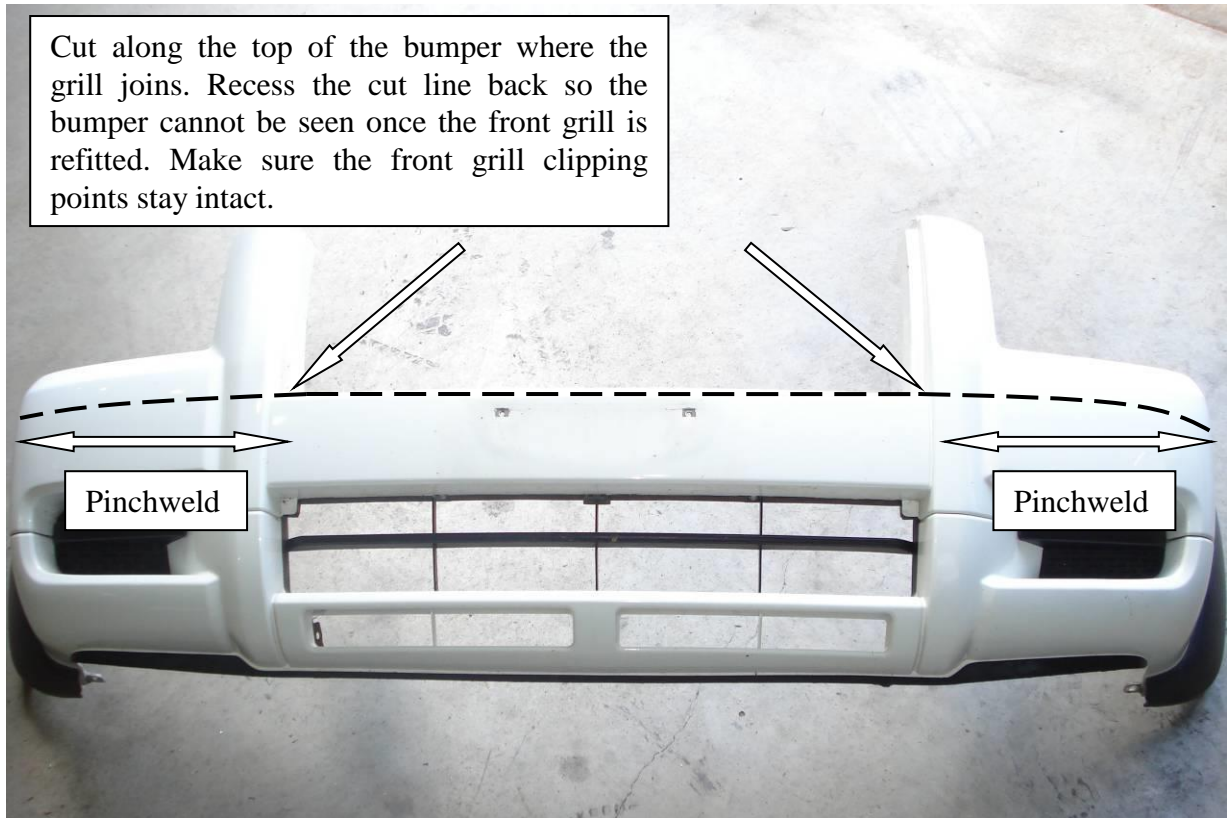

4. Clean the cut edge and fit pinchweld to the left and right sections. Refit bumper onto vehicle.

PK Ranger Bumpercut:

5. Remove bumper from vehicle.
6. Use masking tape and stick it 15mm down from the top edge on the guard side then stick it along the front with the tape edge on the edge of the ridge on the bumper keeping it straight then terminate the tape at the bottom of the grill recess. Repeat this procedure to cut the other side of the bumper. (For best result, cut using a cutting blade on an angle grinder).



7. Clean the cut edge of the two segments that will be reused and fit them back on the vehicle using the OE screws and plastic plugs.
8. Fit the pinch weld rubber supplied over the cut edge.
9. Press the tube inserts into the ends of the wings. Use sikaflex or similar sealant to create watertight seal, and assemble the side tube wings to the bar centre. 4) M10 bolts, flat washers, s/washers, nuts, 2) M12 button head allan bolts **per side** are used to bolt the front of the side wing to the centre.

10. Fit the Ranger mounts to the chassis. Using the two original M12 bolts, 1) M12x35 bolts, 50x5 round flat washer, f/washers, s/washers and nut per side. The mounts bolt to the chassis ends which are located approximately 50mm behind the radiator.
11. Fit the assembled tube bar to the mounts and align the bar to the vehicle. 4) M12 bolts, flat washers, s/washers and nuts **per side**. Tighten all bolts.
12. Fit the front bash plate, the M10 spacers go between the plate and front end. 2) M10x40x1.25 bolts, 40x40x10 spacers, Mudguard washers & S/washers. 2) M10x25 bolts, Mudguard washers, F/washers, S/washers & Nuts.
13. Fit the number plate with the existing screws.
14. This bar & fitting kit is certified as being compatible with the Air Bag system of this vehicle. The compliance sticker is to be attached to the up side of the centre section of the bumper pressing. The vehicle make and model need to be marked on the sticker with a ball point pen after it has been attached to the bar.



Kit Contents

Qty.	Description	Qty.	Description
1	Ranger XROX Bar Centre (C01)	12	12x30mm Bolts
1	Ranger XROX Bar Side Wing R/H (W23)	4	12x40mm button head allan bolts
1	Ranger XROX Bar Side Wing L/H (W24)	18	12mm Spring Washer
2	Bar Mounts (XRFR-1) 1x L/H & 1x R/H	18	12mm Nuts
1	Front Bash Plate (XRFR- 6A) ID: F	10	10x25mm Bolts
4	40x40x5mm Spacers (XRFR- 6C)	10	10mm Spring Washers
4	Plastic Tube Insert 48mm (ID 42mm)	18	10mm Flat Washers
2.2mtr	Pinchweld Rubber - NO Sponge on the side (P/No. Repinch-056)	8	10mm Nuts
1	AIR BAG Protection Sticker	2	10x40x1.25 Fine Bolts
2	50x5mm Round Flat Washers	4	10mm Mudguard Washers
2	12x35mm Bolts	1	Fitting instructions
36	12mm Flat Washers		

Kit Packed by:	Checked By:	Date:
----------------	-------------	-------