

Landcruiser 70 Series VDJ, V8 DT 2007 on

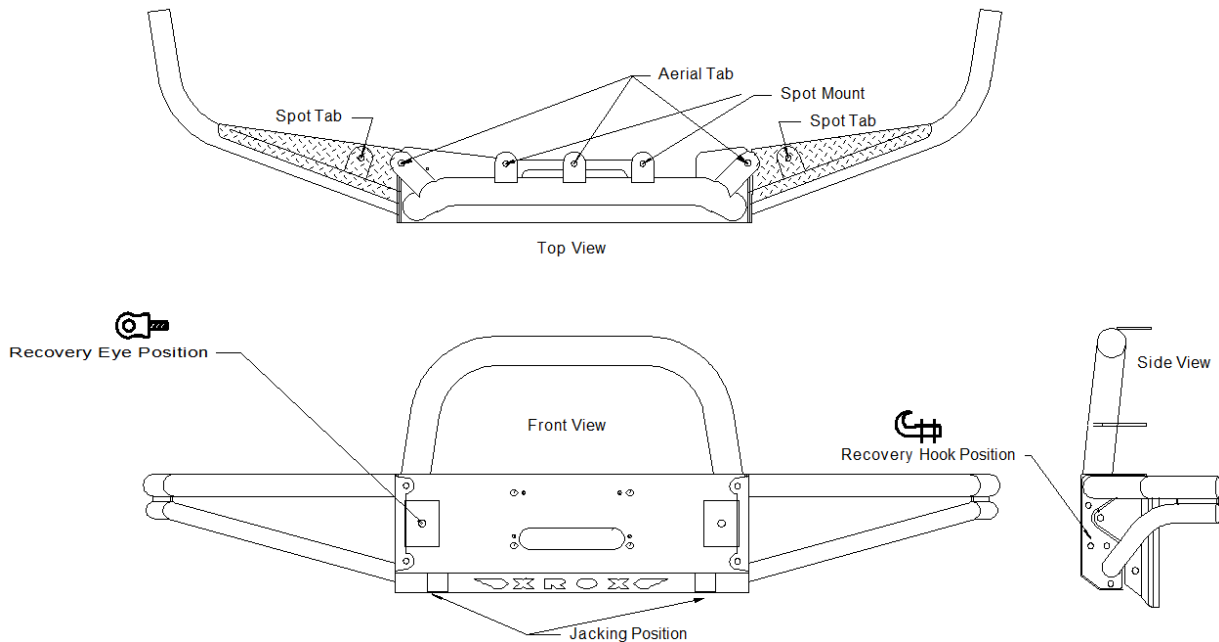

This bar has detachable side wings that can be replaced if damaged; plus 6 spot tab, 3 aerial tabs, 2 jacking positions, 2 recovery eye and 4 hook locations. (Recovery eyes & hooks are not provided in this kit). The bar has been developed to accept up to a 15,000Lb. Warn low mount winch.

This bar & fitting kit is certified as being compatible with the Air Bag system of this vehicle. This sticker is to be attached to the up side of the centre section of the bumper pressing. The vehicle make and model need to be marked on the sticker with a ball point pen after it has been attached to the bar.

NOTE: 50mm Lift Option Available, Part No. XR76-L

Fitting Instructions

1. Remove bumper from vehicle.
2. Fit the tube inserts into the end of the wings. Use sikaflex or similar sealant to create watertight seal, and assemble the side tube wings to the bar centre. 4) M10 bolts, washers, s/washers, nuts, 2) M12 bolts, washers, s/washers, nuts and 2) button head allan M12 bolts per side are used to bolt the front of the side wing to the centre.
3. Fit the Landcruiser XR76 mounts to the chassis. Use 4) OE 10x25 1.25 fine thread bolts on forward holes, 4) 10x30 1.25 thread bolts, flat and spring washers. Use the OE 12x155 bolts to fasten mounts vertically, using 4 thick flat washers per bolt (2 at the head & 2 at the nut). Bash plate also fastens using the 12x155 bolts.
4. Fit the assembled Xrox bar to the mounts and align the bar to the vehicle. 4) M12 bolts, 12mm washers, s/washers and nuts per side.
5. To fit the bash plate, fit the U shape mount to the underside of the chassis to captive nuts adjacent to the bottom of the radiator. Secure with two 10x40x1.25mm bolts, flat washers and spring washers.

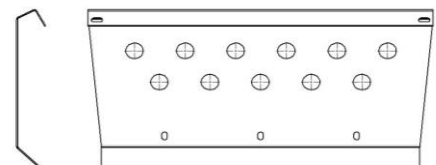

6. Fasten the front end of the bash plate using the OE 12x155 bolts. Fasten the rear of the bash plate to the U shape mount using 3) 10x25mm bolts, spring and flat washers.



7. Tighten all bolts.

8. Fit the number plate with the existing screws.

This XROX® tube bar comprises of both **powder coated** and **painted** parts, the side sections and centre are powder coated while the mounts are painted with a zinc enriched satin black enamel. If at any stage through the product’s life the painted sections show signs of rusting, remove the rust and recoat with satin black zinc enriched enamel.

If a winch is being fitted there are optional number plate holders available. This is an additional cost.

Kit Contents

Qty.	Description	Qty.	Description
1	70 Series Xrox Bar Centre (C01)	32	12mm Flat Washer
1	70 Series Xrox Bar Side Wing R/H (W19)	16	12mm Spring Washer
1	70 Series Xrox Bar Side Wing L/H (W20)	8	12mm Thick Flat Washer
2	70 Series Bar Mounts X76 (XR76-1)	11	10x25 Bolt
2	Plastic Tube Inserts 48mm (ID 42mm)	2	10x40 1.25 Fine Thread Bolt
2	Plastic Tube Inserts 42mm (ID 36mm)	4	10x30 1.25 Fine Thread Bolt
1	XROX Bash plate ID:76 Dwg# XR76-c	11	10mm Nut
1	Bashplate Bracket Dwg# XR76-c 	26	10mm Flat Washer
4	12x40mm Button Head Allan Bolt	17	10mm Spring Washer
12	12x30 Bolt	2	10mm Thick Flat Washer
16	12mm Nut	1	Fitting Instructions

Kit Packed by:	Checked By:	Date:
----------------	-------------	-------