

FITTING INSTRUCTIONS

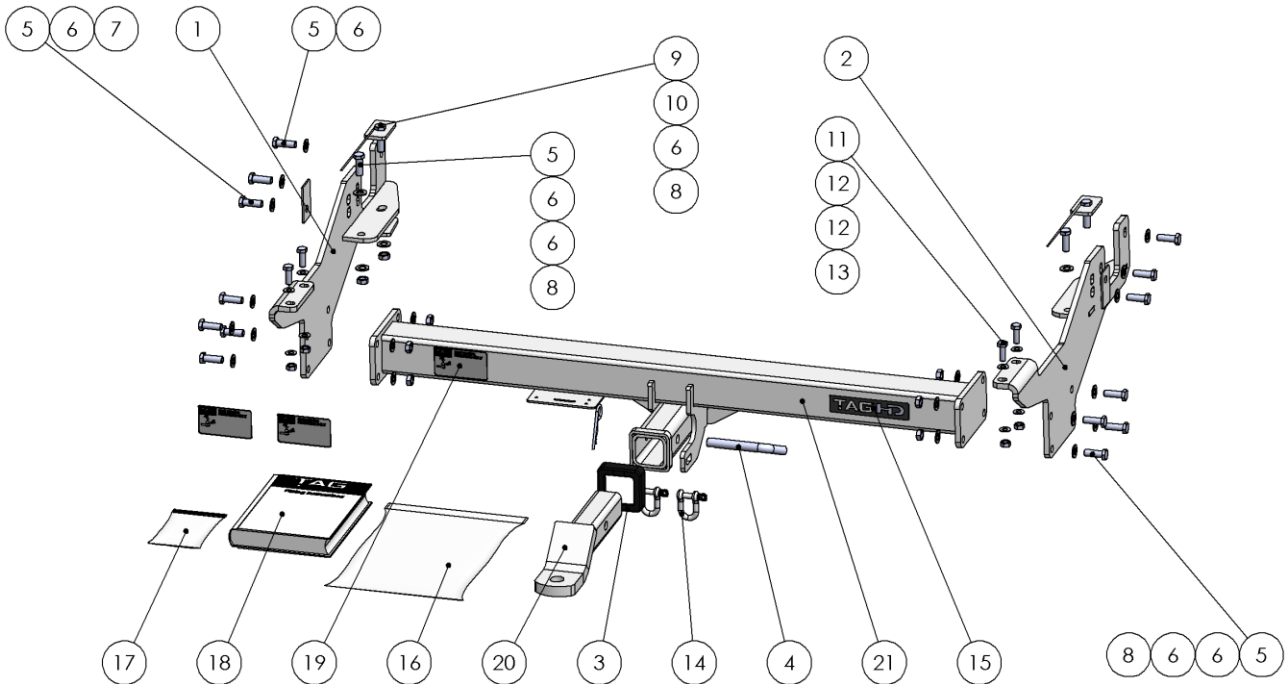

Isuzu Dmax MY21 – Extended Bar – T7H770

Max Towing Capacity: 3500kg	Towbar Weight: 33 kg
Max Ball Load: 350kg	Wiring Harness Part #:
 Tools Required: Spanners, Sockets, Screwdriver, Trim Removal Tool, Torque wrench	



ITEM NO.	DESCRIPTION	QTY.	ITEM NO.	DESCRIPTION	QTY.
1	End Plate Assembly PS	1	12	M10 FLAT WASHER FLAT ROUND ZINC CLEAR	8
2	End Plate Assembly DS	1	13	M10 1.5 Pitch Nut	4
3	Cover Hitch Receiver Collar TAG	1	14	TAG D-Shackle - 10mm, 1000kg, Galvanised	2
4	Class 4 Pin & Clip	1	15	TAG HD Sticker 150 x 33mm	1
5	M12x1.25x35 Bolt	16	16	Poly Bag 260x375mm	1
6	M12 Flat Washer Zinc Clear	28	17	Poly Bag Resealable 150x100mm	1
7	3mm Spacer	2	18	Fitting Instruction - T7H770	1
8	M12x1.25 Nut	12	19	TAG Compliance plate	3
9	M12x1.25x45 Bolt on Plate on 200mm Wire	2	20	L4045 Ball Mount - Powder Coated	1
10	Plate 40x70x6 14mm hole	2	21	T7H765 Welded Assembly	1
11	M10X30 1.5 PITCH B/O GR8.8 METRIC THREAD ZINC CLEAR	4			

FITTING INSTRUCTIONS

Isuzu Dmax MY21 – Extended Bar – T7H770



**ENSURE THAT THE FITTING INSTRUCTIONS ARE READ AND UNDERSTOOD PRIOR TO FITMENT
PLACE THESE INSTRUCTIONS IN THE VEHICLE'S GLOVEBOX AFTER INSTALLATION IS COMPLETED**

Warning:

- This product is for towing purposes only and must only be loaded as shown in your vehicle Owner's Manual.
- This towbar is NOT to be drilled, cut, welded, or modified in any way.
- All load ratings shown are under the assumption your trailer has a functional braking system installed
- When installed in positions other than the one depicted in these instructions the Tow Ball Mount may interfere or obstruct certain features of your vehicle (tailgate opening, Chassis clearance, etc.)

General:

- Before fitting this towbar check installation hardware is included and correct.
- Check that the towbar is suitable for the vehicle make, model and year then make sure any changes to the vehicle design do not conflict with the fitting of this towbar. (Tray, Canopy, Suspension etc.)
- After drilling, blow any filings clear, remove any swarf and treat exposed metal with a rust inhibitor.
- Check behind chassis rail and body panels before drilling to ensure no hazards are present (fuel lines, electrical wires etc.)
- If this vehicle requires a bumper cut out, please check to make sure that your measurements are correct and clear before cutting any panels as some bumper profiles can change. If you are not sure, then please ask your towbar supplier
- The high tensile fasteners supplied with this product are an integral feature to achieving the specified rating, if replacement is required ensure that fasteners of the same grade (8.8) & quality are used. Contact an authorised TAG distributor or the TAG fitment centre - (07) 3208 3022 - if further information is required.

Towbar Maintenance and Care:





It is recommended, when not in use, the Tow Ball Mount assembly and class 4 Pin and Clip is stored inside the car away from moisture to prevent standing water from forming rust. Inspect to ensure, on regular basis, fasteners are torqued to the specifications below and in good condition.

Metric Bolt Torque Settings										
Diameter	Pitch	Grade	Torque	Unit		Diameter	Pitch	Grade	Torque	Unit
M8	1.25	8.8	29	Nm		M12	1.50	8.8	97	Nm
M10	1.25	8.8	57	Nm		M12	1.75	8.8	77	Nm
M10	1.50	8.8	44	Nm		M14	2.00	8.8	122	Nm

FITTING INSTRUCTIONS

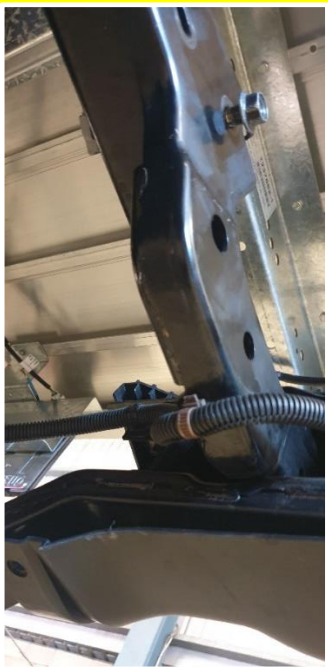

Isuzu Dmax MY21 – Extended Bar – T7H770

M12	1.25	8.8	101	Nm		M16	2.00	8.8	190	Nm
Step 1		Remove Bumper Cover								
Instructions										
<p>Rear bumper can either be removed or remain on vehicle for disassembly. Lane departure sensors <u>do not</u> need to be removed from mounting locations.</p> <ol style="list-style-type: none">Disconnect the bumper wiring loom from the chassis plug.Remove the wiring loom from the bumper bar mounting brackets.Remove 4x plastic scrivets from the underside of the step section.Peel outer edge of top covers up gently to release from retaining clips.Using a trim tool or similar, release the clips retaining the plastic moulding to the steel reinforcement whilst gently pulling it outward. See photo for location of clips.Remove the bolts fastening the bumper brackets to the bumper & discard.Remove the bumper brackets from the chassis and discard.										
										

FITTING INSTRUCTIONS

Isuzu Dmax MY21 – Extended Bar – T7H770



Step 1 Continued

Instructions

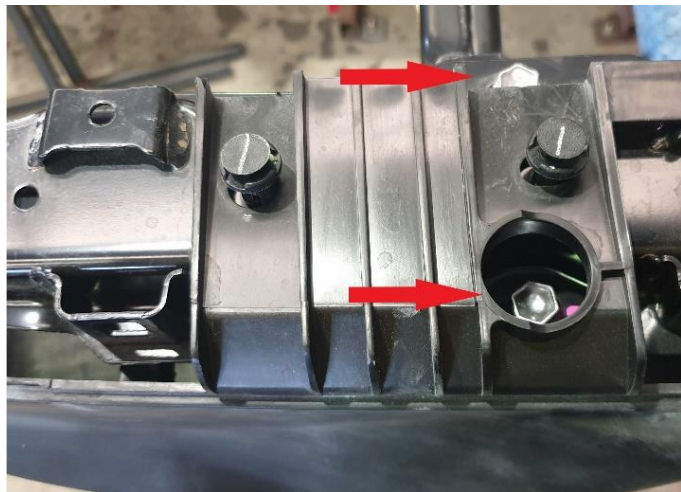
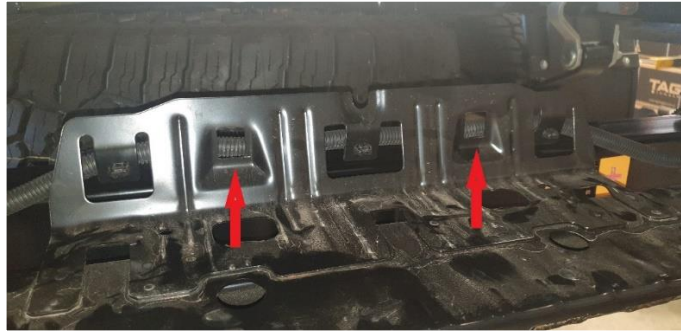

FITTING INSTRUCTIONS

Isuzu Dmax MY21 – Extended Bar – T7H770

TAG

Step 2 | Fit Towbar

Instructions

- Secure side plate to the chassis using M12 bolts. Insert nut plate into chassis and secure loosely with M12 bolts from below.
- Loosely secure the towbar cross member to the side plates using M12 bolts, washers & nuts.



Step 3 | Fit Bumper

Instructions

- Lift bumper up to towbar end plate and insert M10 bolts. Loosely secure with M10 nuts & washers. **Note: To add nuts to the bolts, slide the bumper L & R whilst loose to gain room for your hand.**
- Tighten towbar end plate & crossmember bolts to torque specification on page 2.
- Align / centre the bumper bar to the vehicle & tighten bumper bar bolts.
- Reconnect wiring loom.
- Re-install plastic bumper cover.



FITTING INSTRUCTIONS

Isuzu Dmax MY21 – Extended Bar – T7H770



Step 4 | Fit Ball Mount and Apply Door Sticker

Instructions

- Attach plastic hitch surround to receiver.
- Insert ball mount into hitch receiver and secure with the pull pin and R-clip.
- Apply one of the compliance labels to the pillar of the driver's door.
- Leave the remaining label & the fitting instructions in the vehicle handbook.



WARRANTY STATEMENT

The manufacturer of TAG branded products, warrants your TAG Towbar for its full product life under the following conditions:

- You can show proof of purchase.
- The towbar has been correctly installed by a suitably qualified installer.
- The towbar has not been modified or abused in any way and has only been used for the purpose intended.
- The towbar was not fitted second hand to your vehicle.

The extent of this warranty includes materials and workmanship used in the manufacture of the towbar and is to the equivalent value of current, full replacement cost. Nothing stated or implied in this warranty limits in any way, the statutory rights that you may have.

To make a claim visit the original installer in the first instance or, if you are unable to or are not satisfied with their help, then contact us directly by email at warranty@tagtowing.com