



RHINO-RACK®

ISUZU D-MAX GEN 3 / MAZDA BT-50 GEN 3

HOLDEN COLORADO GEN 2 / ISUZU
D-MAX (LS-U/LS-M/X-RUNNER) GEN 2

Base Kit - RCP71-BK

Important:

1. Check the Rhino-Rack website to ensure you have the latest issue of these instructions.
2. Please refer to your fitting instruction to ensure that the roof racks are installed in the correct locations.
3. Check the contents of kit before commencing fitment and report any discrepancies.
4. Place these instructions in the vehicle's glove box after installation is complete.
5. These instructions must be followed for warranty to be upheld.

Fit Time: 1 hour

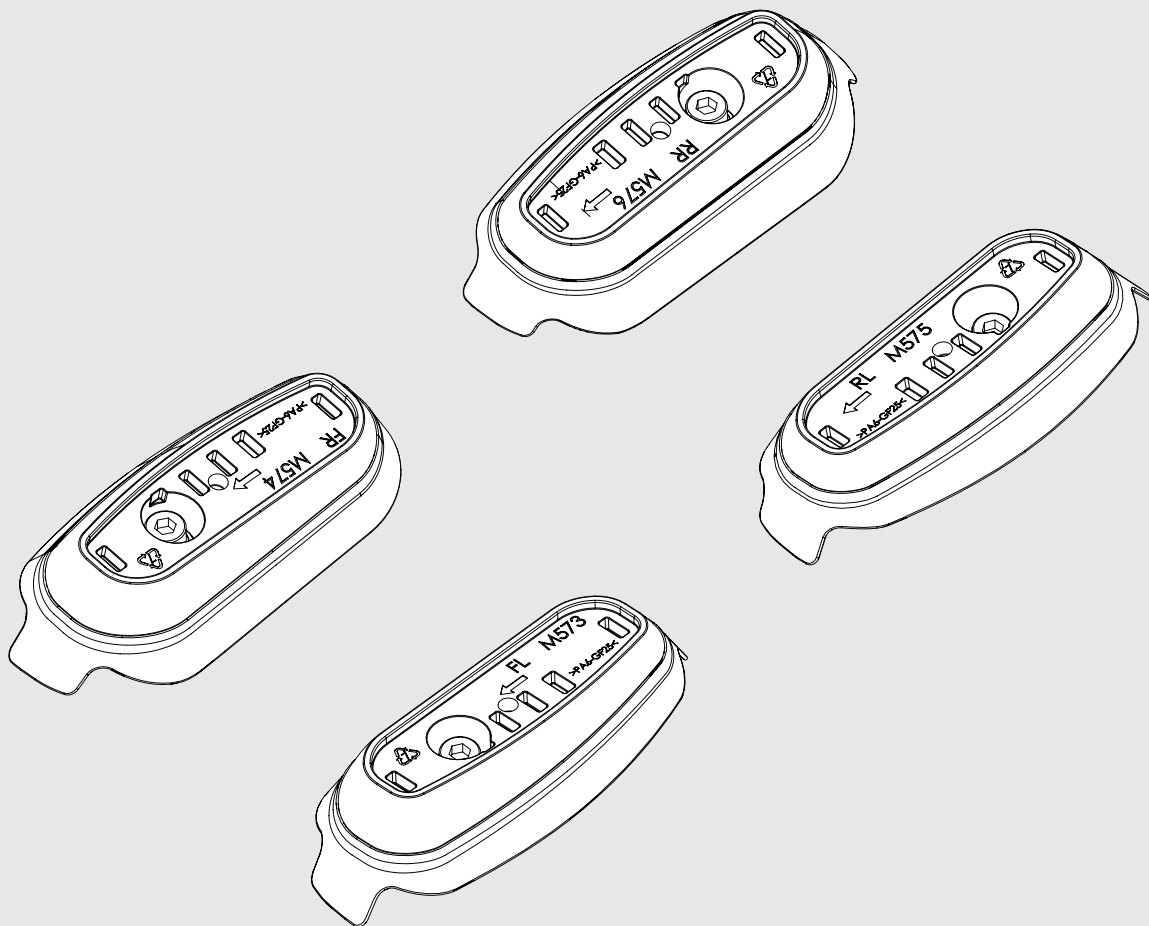

Rhino-Rack AUSTRALIA
22A Hanson Pl,
Eastern Creek, NSW, 2766
(02) 8846 1900
rhinorack.com.au

Rhino-Rack USA
Unit D, 2450 Airport Blvd,
Aurora, CO, 80011
877-744-6622
rhinorack.com

Rhino-Rack CANADA
19100 Airport Way
Pitt Meadows, BC V3Y 0E2
rhinorack.ca

Document No: R2624
Issue No: 03
Issue Date: 28/07/2021



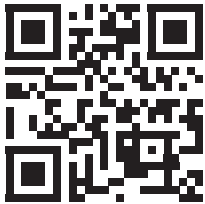

Carrying Capacity

Check your vehicle owners hand book for vehicle maximum carrying capacity. Please ensure you use the vehicle manufacturer’s maximum roof allowance if it is lower than the figure listed in this instruction. Load must be evenly distributed over the system.

VISIT THE ONLINE CALCULATOR FOR CURRENT SYSTEM LOAD LIMIT DATA

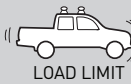

DYNAMIC CROSS BAR LOAD LIMIT:
***USE THE VEHICLE MANUFACTURER’S MAXIMUM ROOF ALLOWANCE IF IT IS LOWER THAN THE FIGURE LISTED**

 CARGO UP TO 95 KG 209 lbs	 SYSTEM WEIGHT 5 KG 11 lbs	+ =	 LOAD LIMIT UP TO 100 KG 220 lbs	OR	 Max kg *VEHICLE MANUFACTURER’S ROOF LOAD LIMIT
------------------------------------------------------------------------------------------------------------------------------------	------------------------------------------------------------------------------------------------------------------------------------	--------	-------------------------------------------------------------------------------------------------------------------------------------------	----	-------------------------------------------------------------------------------------------------------------------------------------------------

 **STATIC LOAD LIMIT: UP TO 250KG / 550LBS***



Cargo Load Limit

Total permissible weight allowed on top, and attached to roof racks whilst the vehicle is in motion.

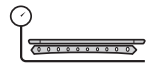

System Weight

Total weight of the roof rack system. (e.g. Cross bars, Backbone, Platform)



Max System Load Capacity

Please ensure you use the vehicle manufacturer’s maximum roof allowance if it is lower than the figure listed in the fitting chart.



Vehicle Manufacturer’s Load Limit

Total permissible weight attached to the roof of the car. This is inclusive of the weight of the roof rack system.

Warning

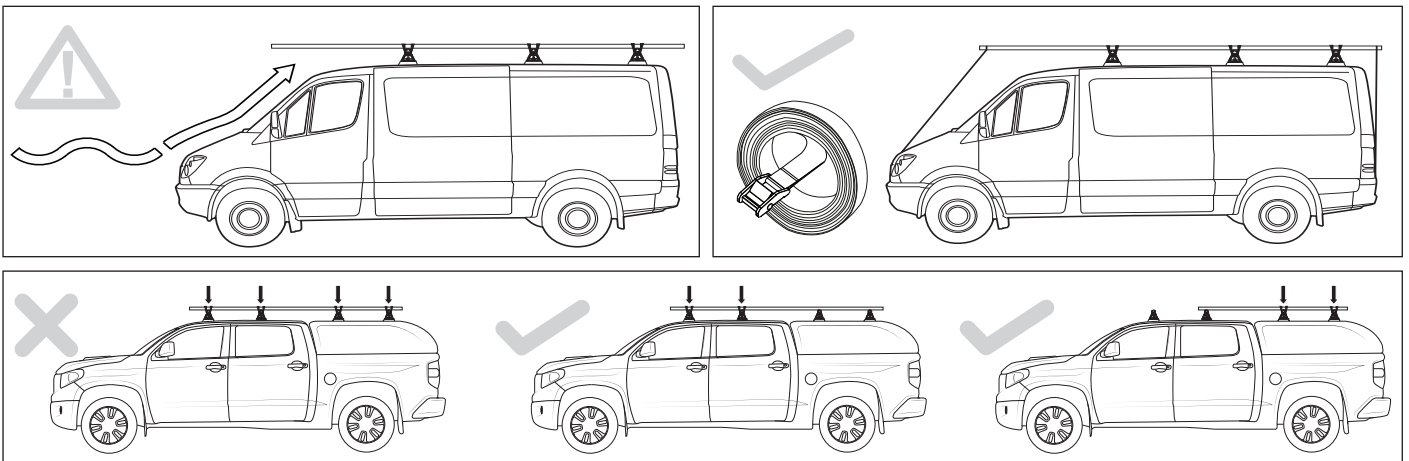

- Check part number or kit is correct for use with your vehicle.
- Do not attempt to fit the rack system to your vehicle unless you fully understand these fitting instructions. Please direct any questions regarding fitting to the dealer from where the roof racks were purchased.
- Off-road conditions can be much more rigorous. Extreme care must be taken on any driven path that does not contain a surface protection layer (tar/bitumen).
- Roof racks must be removed when vehicle is put through an automatic car wash.
- With utility vehicles, the cabin and the canopy move independently. Roof racks and vehicle can be damaged if the item transported is rigidly fixed at points on both the cabin and canopy. Instead, rigidly fix to either the cabin roof racks or the canopy roof racks.
- Always ensure you fasten your load securely.
- Use only non-stretch fastening ropes or straps to attach cargo to your load.

In service maintenance checks

- All bolt connections should be checked after driving a short distance when you first install your roof racks.
- All bolted connections should be checked again at regular intervals (weekly is recommended, depending on road conditions, usage, loads and distances travelled).
- All bolted connections should be checked each time they are re-fitted.
- Off-road conditions are more rigorous. Check all bolted connections and your load more regularly.
- Ensure that your vehicle manufacturer's GVM, and gross axle weights are not exceeded (refer to vehicle owner's manual).

Torque Settings

Unless stated otherwise in these instructions, all fasteners should be set to the following torque settings:

M6: 4-5Nm (3-4lbs/ft),











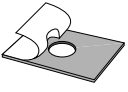

M8: 8-10Nm (6-7.5lbs/ft)

M10: 16-18Nm (12-13lbs/ft).

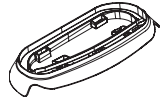
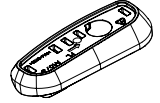
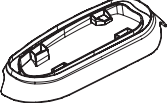
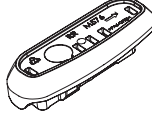
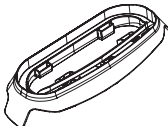
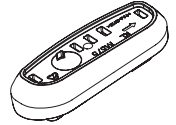
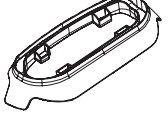
Note for Dealers and Fitters

It is your responsibility to ensure these fitting instructions are given to the end user or client. These instructions remain the property of Rhino-Rack Australia Pty. Ltd. and may not be used or changed for any other purpose than intended.

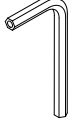
Parts List

<p>M8 x 30mm SHCS</p>  <p>A x4</p>	<p>M8 Spring Washer</p>  <p>B x4</p>	<p>M8 Flat Washer</p>  <p>C x4</p>	<p>7mm x 4mm O-ring</p>  <p>D x4</p>
<p>Butyl Patch</p>  <p>E x4</p>	<p>Front Right Pad (FR) fin-loc</p>  <p>F x1</p>	<p>Front Right Skirt (FR)</p>  <p>G x1</p>	<p>Front Left Pad (FL) fin-loc</p>  <p>H x1</p>
<p>Front Left Skirt (FL)</p>  <p>I x1</p>	<p>Rear Right Pad (RR) fin-loc</p>  <p>J x1</p>	<p>Rear Right Skirt (RR)</p>  <p>K x1</p>	<p>Rear Left Pad (RL) fin-loc</p>  <p>L x1</p>
<p>Rear Left Skirt (RL)</p>  <p>M x1</p>	<p>Pad Cover Plate</p>  <p>N x4</p>	<p>M6 x 30mm Hex Setscrew</p>  <p>O x4</p>	<p>M6 Spring Washer</p>  <p>P x4</p>
<p>M6 x 16mm Flat Washer</p>  <p>Q x4</p>	<p>6mm Allen Key</p>  <p>R x1</p>	<p>Nylon Scraper</p>  <p>S x1</p>	<p>Instruction</p>  <p>T x1</p>

Tools Required:

- T1 - Masking Tape
- T2 - Tape Measure
- T3 - Pencil/Marker
- T4 - Chisel
- T5 - Mallet
- T6 - Flat head Screwdriver
- T7 - Knife
- T8 - Cold Galvanising paint
- T9 - Small Paint Brush
- T10 - Caulking gun with Butyl Mastic (for Colorado Gen2 / D-Max (LS-U/LS-M/X-Runner) Gen2 only)

1 Repeat to opposite side of vehicle

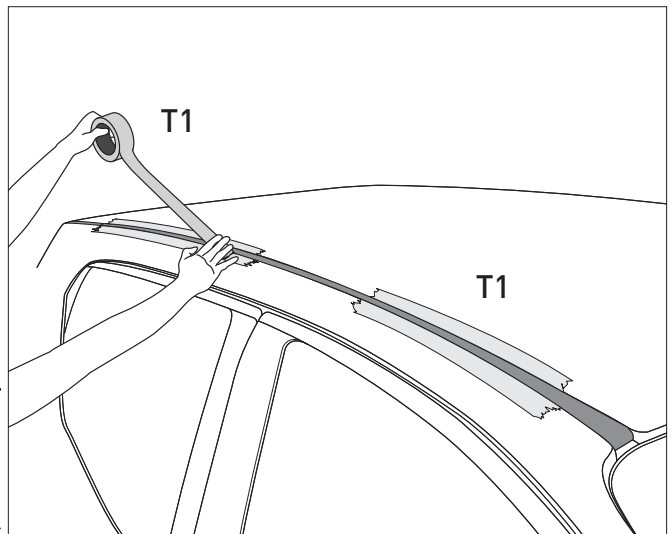
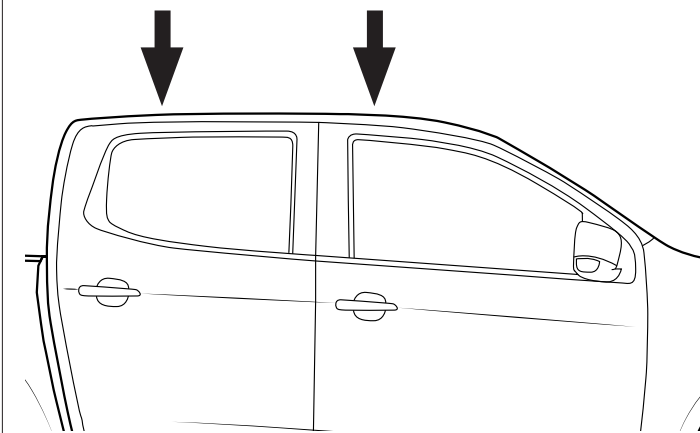

2 Repeat to opposite side of vehicle

• **FOR BT-50 & D-MAX GEN 3**

Measure from end of rear ditch.
Continue to step **3**

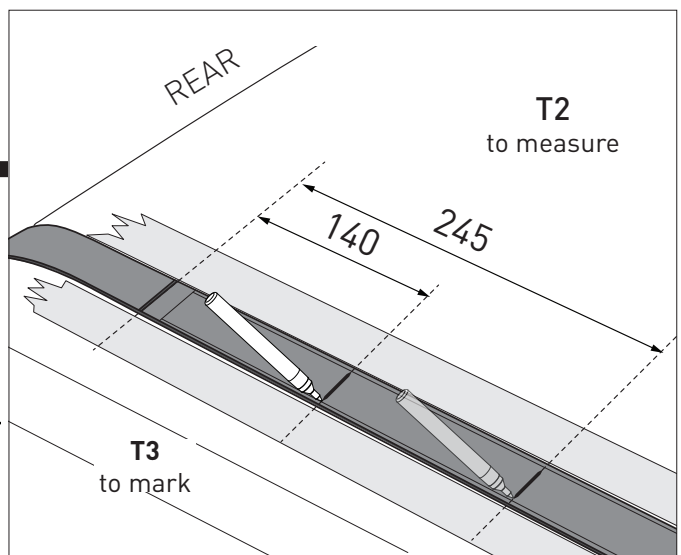
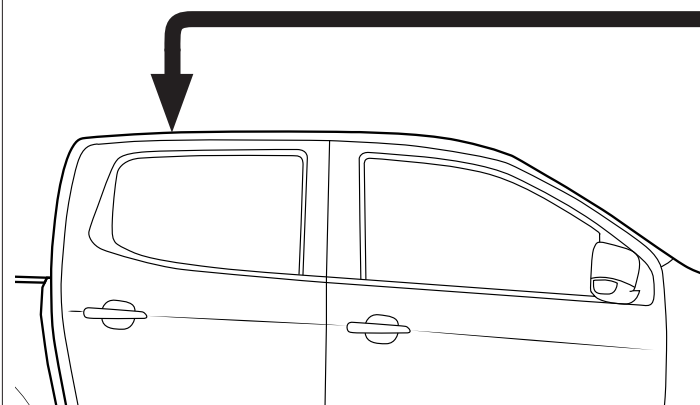

• **FOR COLORADO & D-MAX GEN 2**

Measure from windscreen rubber
Continue to step **3**

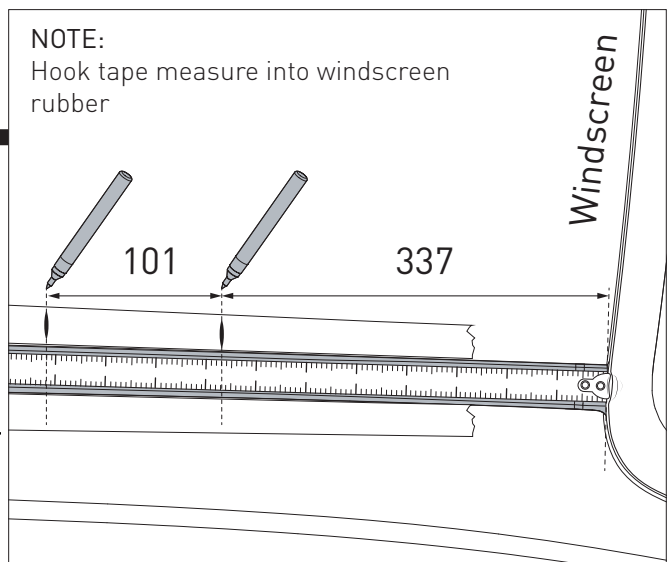
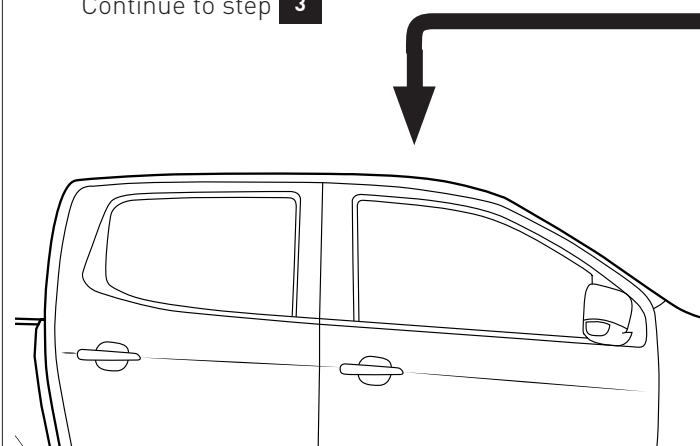

3 Measure & mark then repeat to opposite side of vehicle

• **FOR BT-50 & D-MAX GEN 3**

Measure from end of rear ditch.

Continue to step **4**

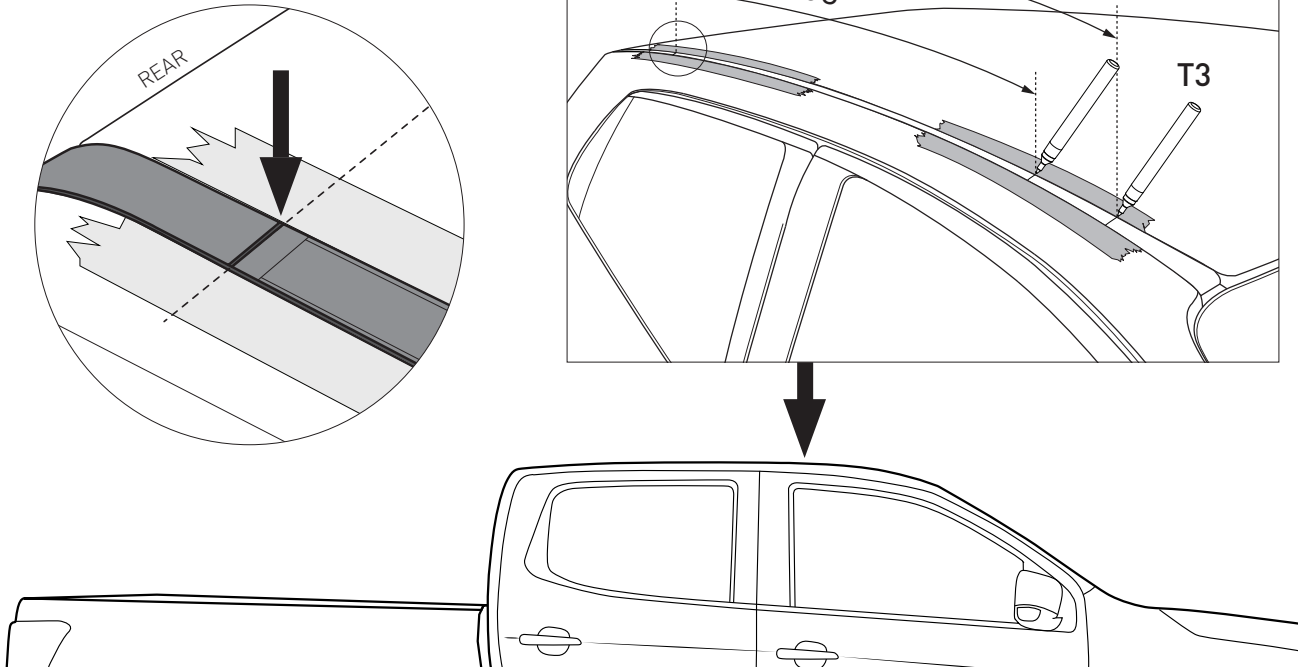

• **FOR COLORADO & D-MAX GEN 2**

Measure from closest front marking

Continue to step **4**

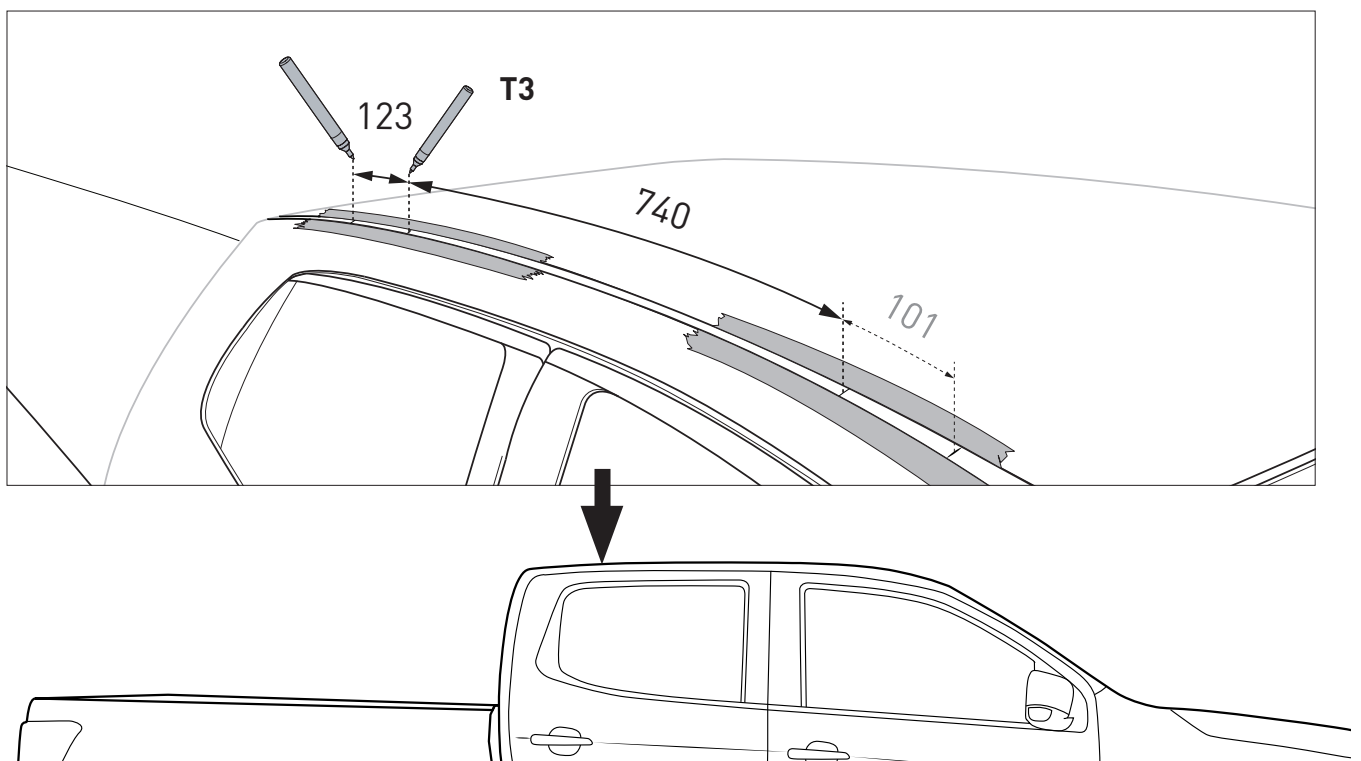

RCP71-BK Instructions

4

Firmly indent the two measured marks on the entire width of the ditch rubber steel reinforcement strip at the front of the vehicle.

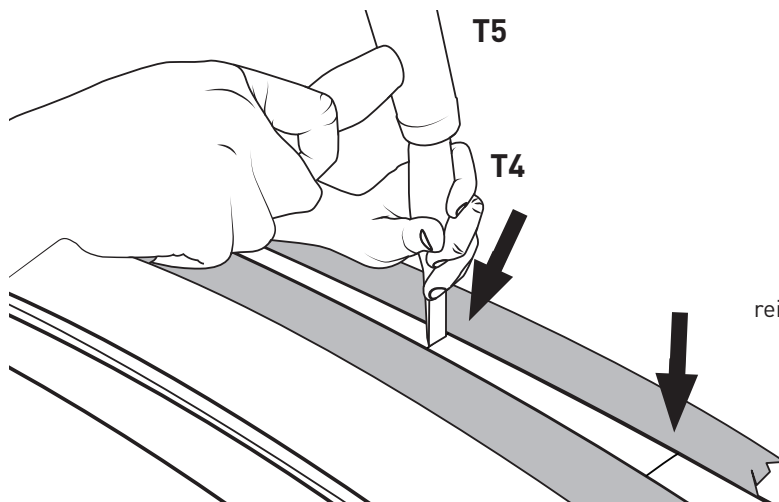

Steel reinforcement strip

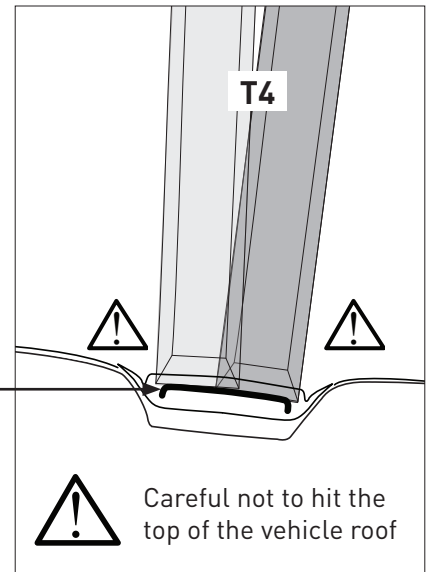

5

Break through the metal strip between the two measured marks made in step 4

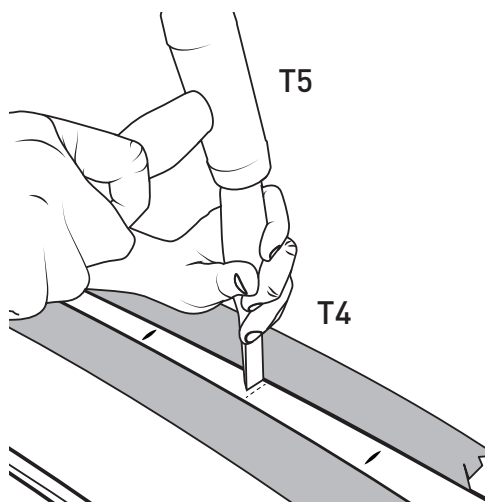

5a

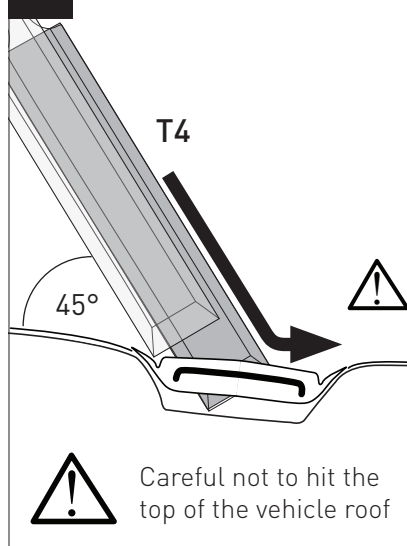

5b

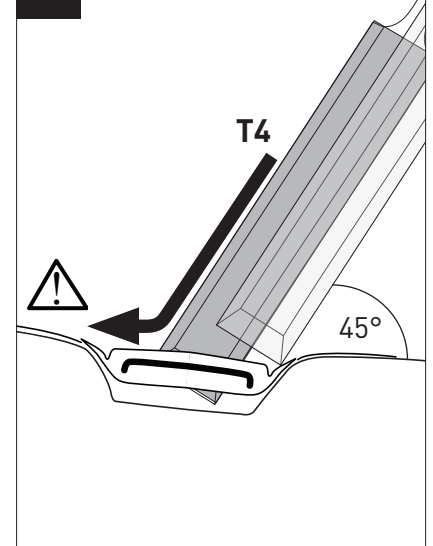

6

If necessary, use a knife to cut through any rubber remaining on either side of the metal strip.

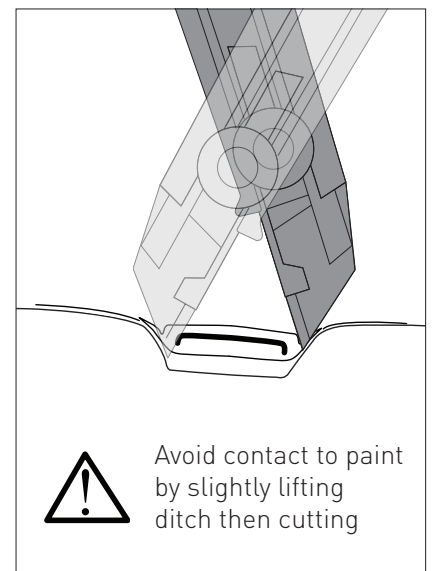
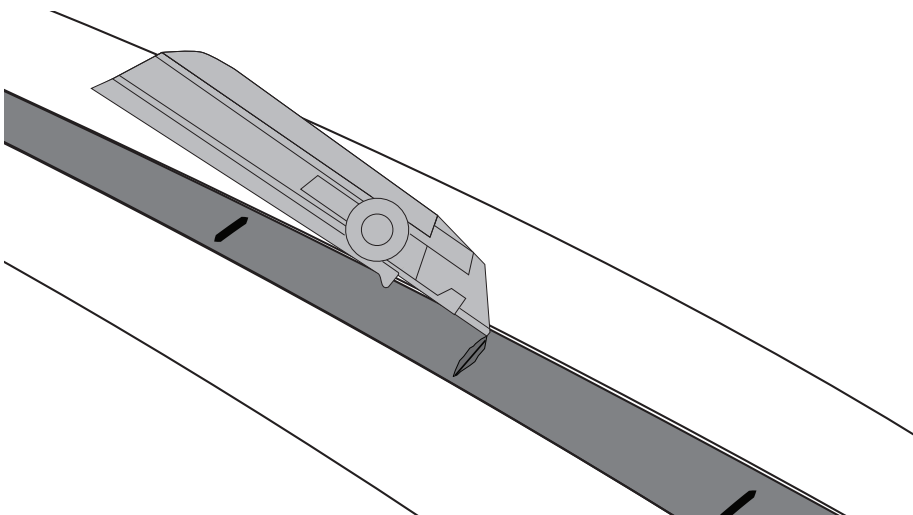

7 Wedge a flat head screwdriver underneath the cut in the ditch rubber and lift to separate

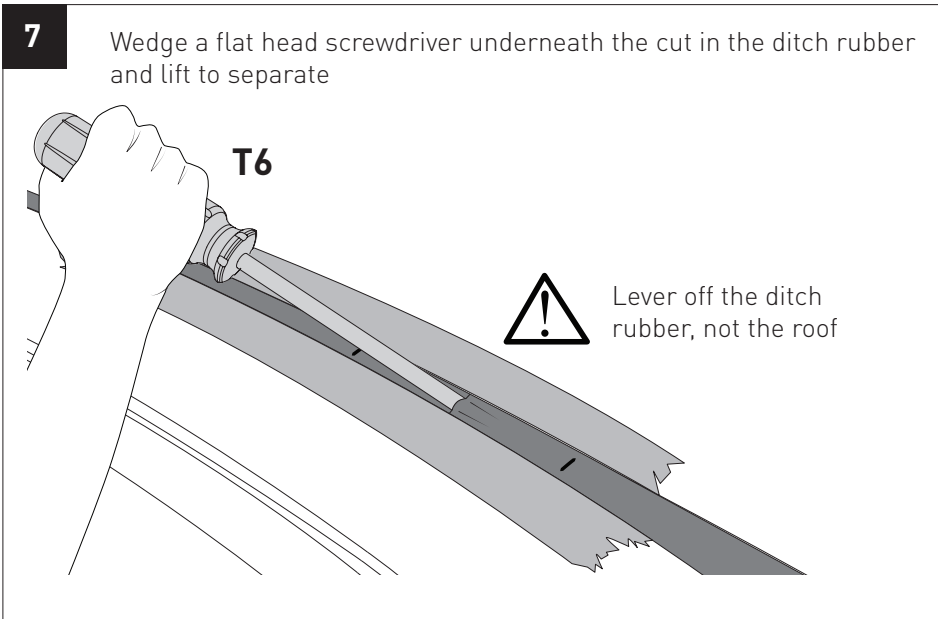

T6

! Lever off the ditch rubber, not the roof

7a Careful not to hit the bottom of the roof ditch

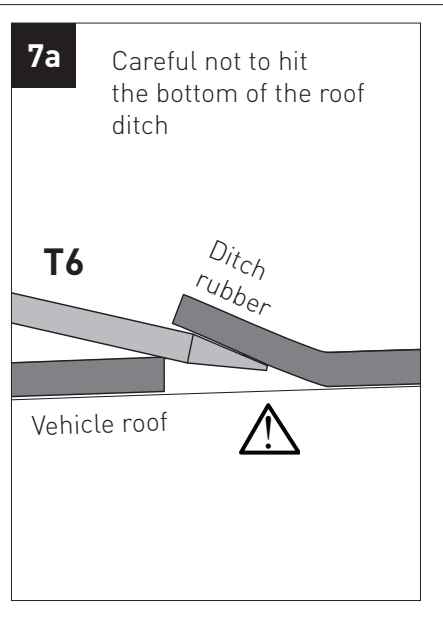

T6 Ditch rubber

Vehicle roof !

8 Work the strip back & forth to snap off then cut through ditch rubber with a knife. Repeat to ditch rubber B.

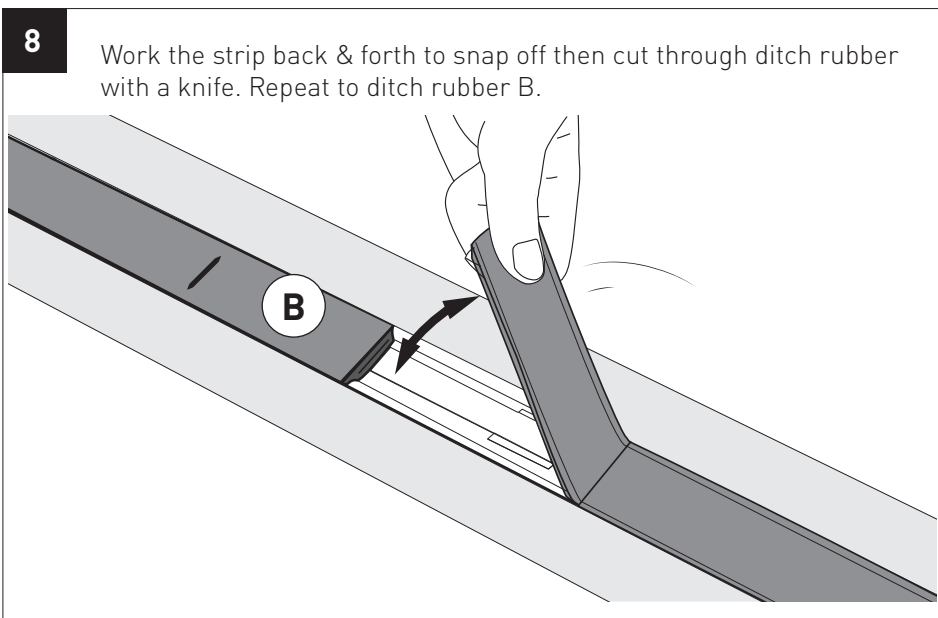

B

8a Repeat steps **4** - **8a** for the rear ditch mount markings



T7

9

- **FOR BT-50 & D-MAX GEN 3**
Follow this step then continue to step **11**
- **FOR COLORADO & D-MAX GEN 2**
Follow this step then continue to step **10**

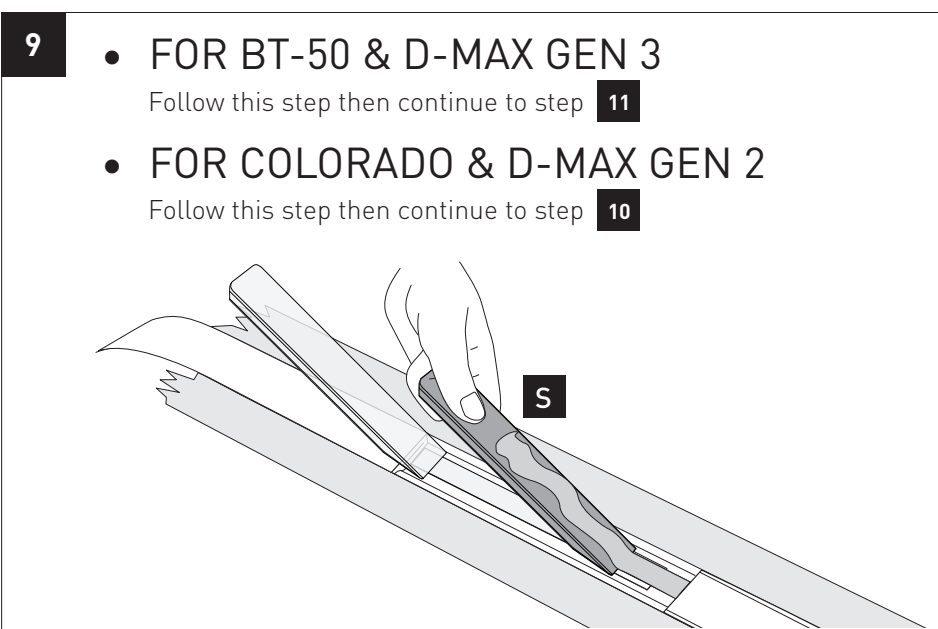

S

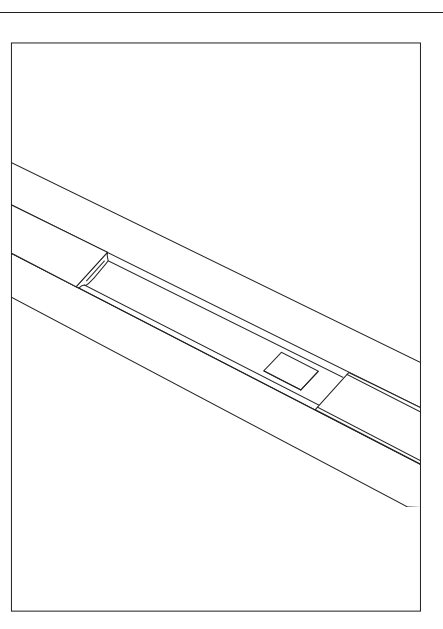

10 • **FOR COLORADO & D-MAX GEN 2**

Inspect area where roof pads will sit. Remove any excessive sealant as it may prevent the roof pads from sitting evenly, and effectively sealing against water leaks.

Continue to step **11**

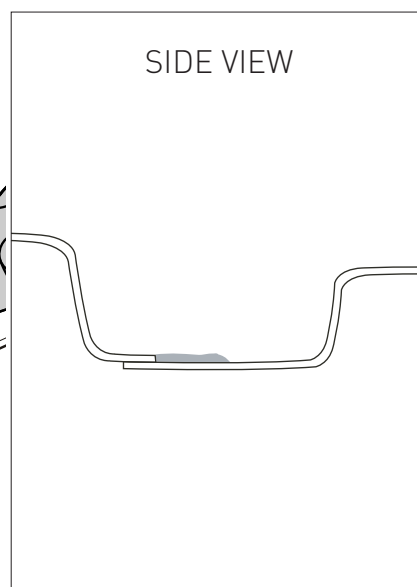
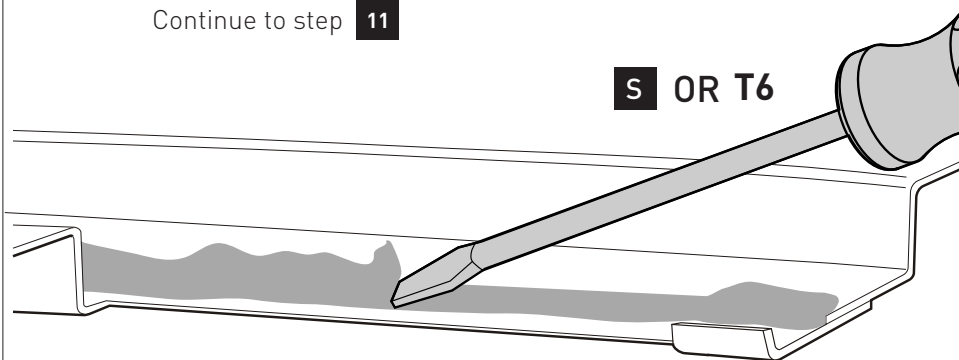

11

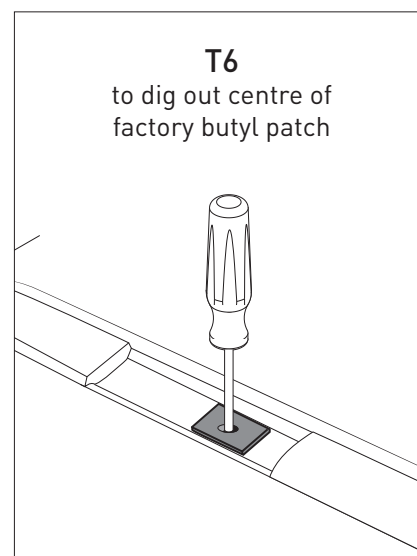
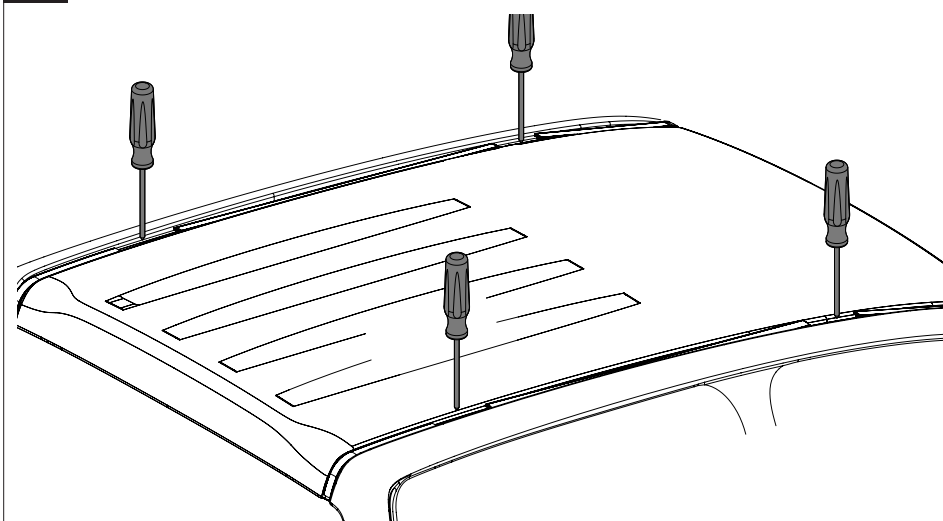

12

Test exposed threads with M8 screws. Remove any material causing binding.

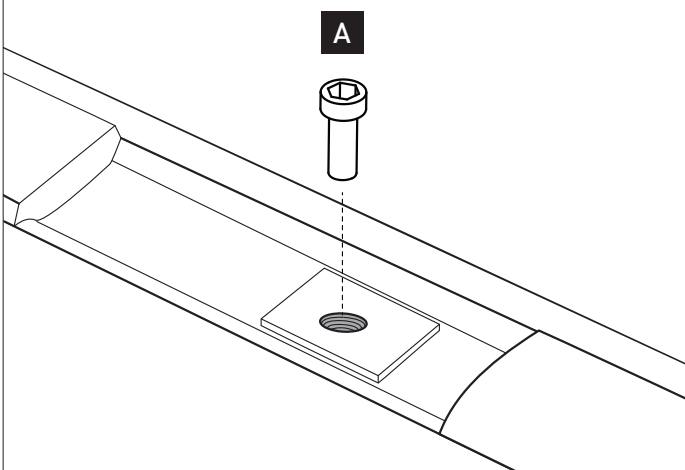

13

Apply cold galvanising paint to any marks in the vehicle paint from the chisel. Repeat steps 11-13 to all four pads

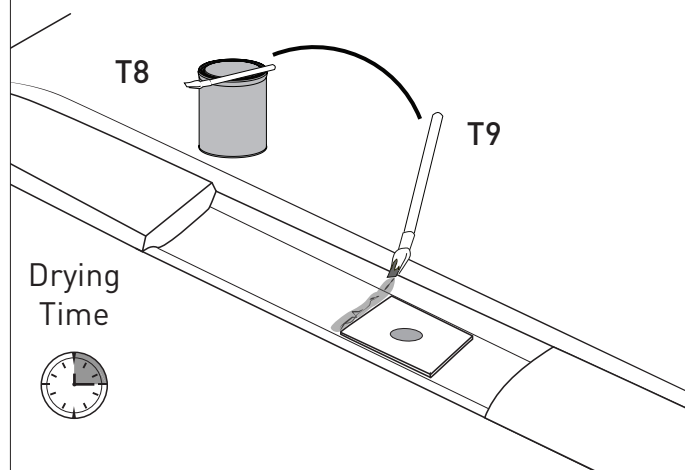

14

14a

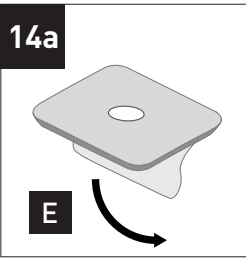

14c

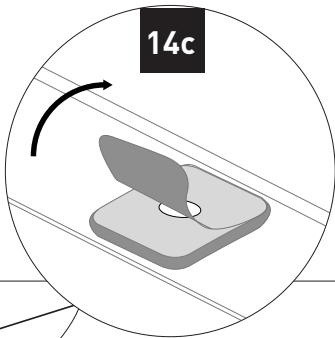

Repeat to opposite side of vehicle

- FOR BT-50 & D-MAX GEN 3
Continue to step 16
- FOR COLORADO & D-MAX GEN 2
Continue to step 15

14b

E

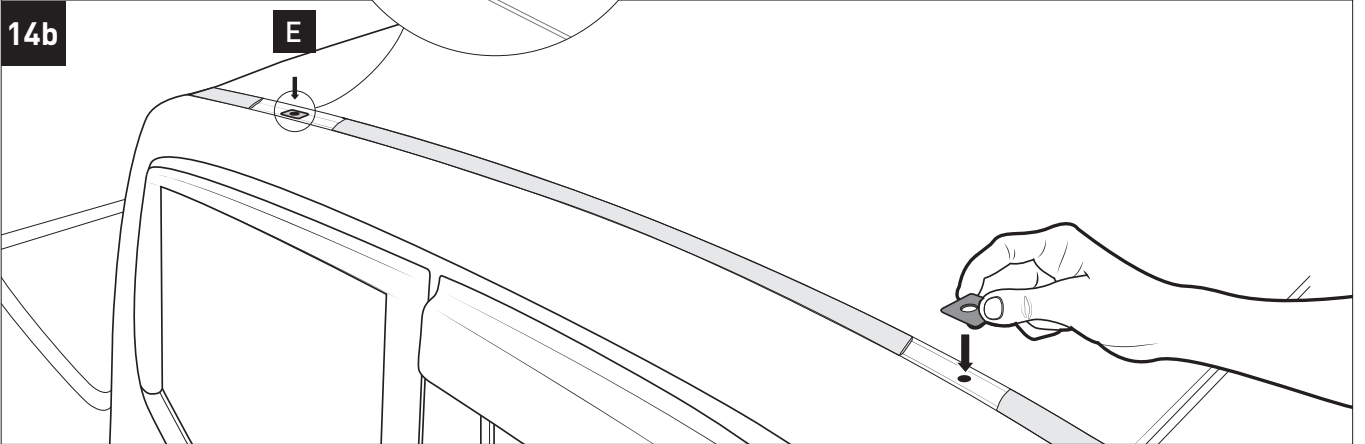

15

FOR COLORADO & D-MAX GEN 2

Apply sealant over the full lengths of the exposed joint

T10

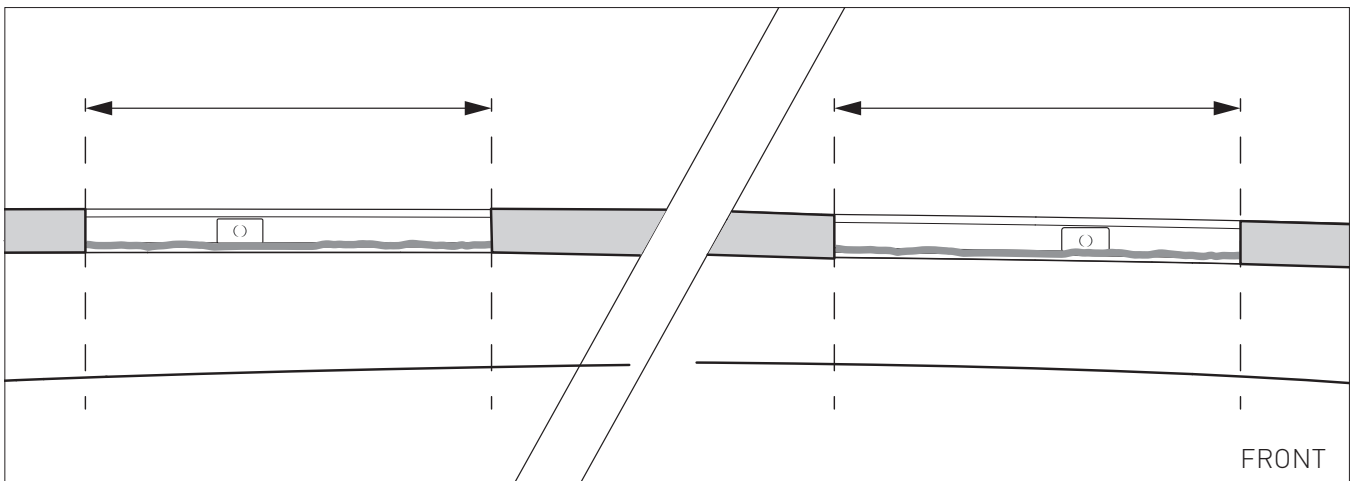
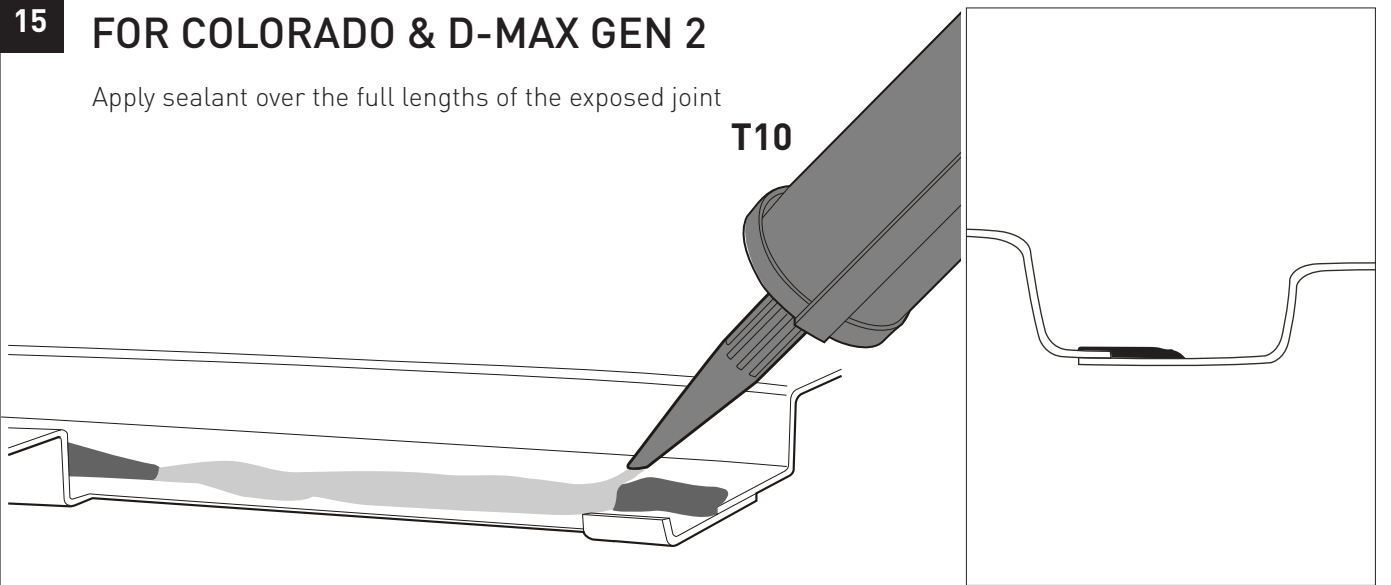

16

Refer to Step 19 to assemble pads to skirts ensuring arrows are facing the same direction.

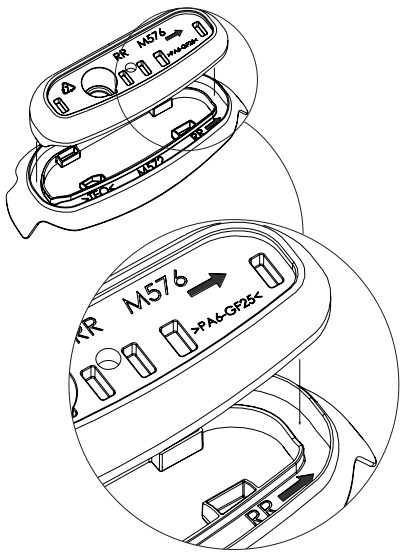

17

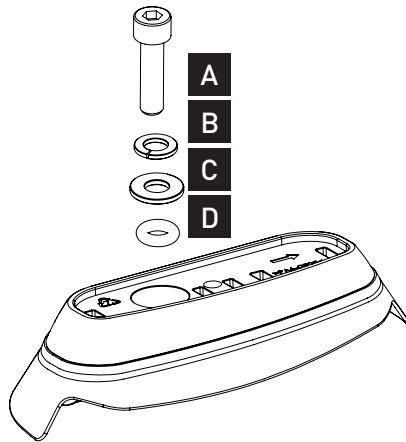

18

Arrows to face the front of the vehicle

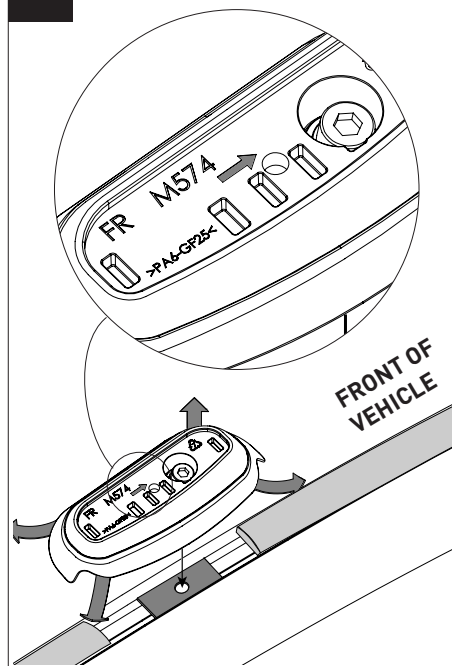

19

RL M575
M571

FL M573
M569

R

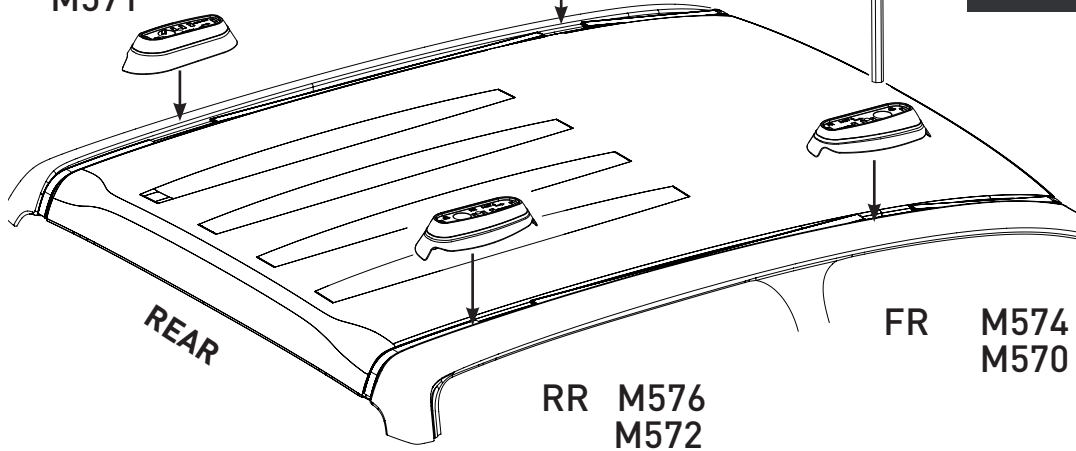

20



When not in use, attach pad cover plates as removing base pads will compromise sealing of roof attachment



J

