

HARDKORR



10A BATTERY CHARGER

INSTRUCTION MANUAL

V1.0 - APRIL 2023

HKPBATCHG10A

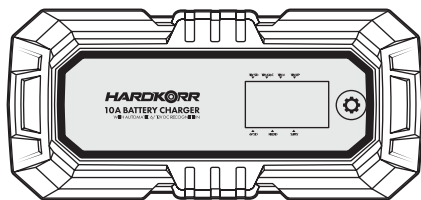

CONTENTS

1x	10A Battery Charger
1x	SAE plug to alligator clamps adapter
1x	SAE plug to ring terminals adapter (15A fused)

SPECIFICATIONS

Operating voltage	220-240V 50/60Hz
Charging current (12V Standard Lead Acid)	Max. 10A
Charging program (12V LiFePO ₄)	14.6V DC / 10A
Charging program (12V Maintenance)	14.4V DC / 2A
Charging program (12V Reconditioning)	16.5V DC / 2.5A
Charging program (6V STD)	7.5V DC / 2A
Compatible battery capacity	4-200Ah
Supply function max. output	10A
Dust/water protection	IP65
Operating temperature	-20°C – 40°C
Safety features	Short circuit protection, Overload protection, Reverse polarity protection, Overcharging protection, Overtemperature protection

FUNCTION OVERVIEW

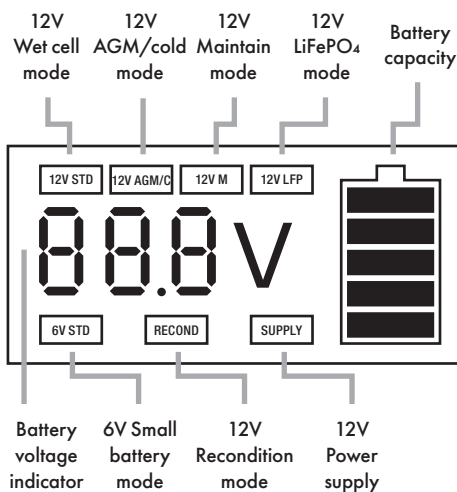

FUNCTION BUTTON

Short press the function button to cycle between 12V Wet Cell, 12V AGM/SLA, 12V Maintenance and 12V LiFePO₄ modes.

Long press the function button to cycle between the 6V Battery Charge, 12V Recondition, and 12V Power Supply modes.

To exit additional modes, long press function button again until display goes back to default view.



NOTE: READ ALL INSTRUCTIONS AND WARNINGS CAREFULLY BEFORE USE.

CHARGING

The battery charger is a microprocessor controlled automatic charger, it is suitable in particular for charging maintenance-free batteries and for the long-term charging and maintenance-charging of batteries which are not in constant use, e.g. for classic cars, recreational vehicles, ride-on mowers and alike.

The integrated microprocessor enables charging in several steps. The final charging step, maintenance charging, maintains the battery capacity at 95–100% and therefore keeps the battery fully charged at all times. The charging operation does not need to be monitored. Do not leave the battery unattended if you charge it over an extended period of time, so that you can disconnect it from the mains power supply in the event of a fault in the charger.

The battery charger is designed for mobile use only and not for installation in caravans, mobile homes or similar vehicles. The battery charger cannot be used as an alternate power supply, e.g. while changing a battery. Do not expose the charger to rain or snow.

NOTE: IDLE POWER DRAW

If the battery charger mains plug is pulled out but the charger cables are still connected to the battery, the charger will draw a small amount of electricity from the battery. We recommend that you always completely remove the charger from the battery when not in use.

OPERATION

1. INTENDED USE

The product is designed to charge and maintain 6V/12V wet cell, AGM/SLA and LiFePO₄ batteries with a capacity of 4 - 200 Ah. The charger has been optimised to maintain the battery of your vehicle when it is not being used over longer periods of time, for example when in storage. The charger is designed to charge Lithium, Gel, AGM and standard lead-acid batteries. Other use may damage the product or increase the short circuits, fire, or electric shock.

2. PREPARING TO CHARGE

Where possible, the battery should be removed from the vehicle prior to charging.

The battery should be charged in a well ventilated area.

The battery terminals should be cleaned with a solution of baking soda and water before attaching to the charging unit.

Consult the user manual of your battery prior to charging.

Determine voltage of battery by referring to the vehicle's manual and make sure the output voltage mode is correct.

3. CONNECTION

This unit should be connected to the battery's terminals before plugging the charger into 240V.

CHARGING THE BATTERY OUTSIDE THE VEHICLE

Connect the battery clips or ring terminals to the battery in the following order:

1. Connect the positive lead (red) to the positive battery terminal (typically marked +/+ve or P).
2. Connect the negative charging lead (black) to the negative battery terminal (typically marked -/-ve or N).

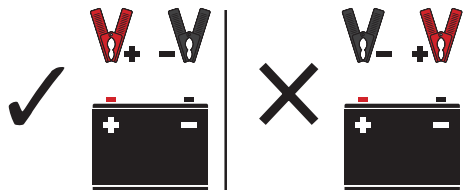

3. Plug in the 240V connection into your AC/mains outlet.

4. Use the function button to set the appropriate charge setting.

The battery has an inbuilt auto memory function. The charging mode last used before being turned off will be the mode the charger starts with.

To disconnect, start by removing the charger from the 240V/AC point, then remove the negative connection, followed by the positive connection.

CHARGING THE BATTERY WITHIN THE VEHICLE

1. Connect the black negative lead (black) to an earth point (ie. vehicle chassis) well away from any fuel line or hot points.
2. Connect the positive lead (red) to the positive battery terminal (typically marked +/ve or P).

NOTE: POSITIVE EARTHING

Under normal circumstances, the negative battery pole is connected to the bodywork and you proceed as described above. In some exceptional cases it is possible that the positive battery pole is connected to the bodywork (positive earthing). In this case, connect the black charger cable to the negative pole on the battery, then connect the red charger cable to the bodywork at a point away from the battery.

4. CHARGING

1. First make sure your battery is a 6V or 12V battery. Do not charge batteries with different operating voltages.
2. Connect the battery charger to the power supply.
3. Select the appropriate charging mode for your batteries with the "Mode" button. Refer to *Function Overview* for a description of the individual operating modes.
4. Then, connect the battery charger to the battery with the correct polarity. If connected with reverse polarity or short-circuit at the clamps "Err" will be lit.
5. This battery charger is equipped with an automatic memory function, i.e. if the last charging mode was 12V Recond., that mode will be selected when the charger is next powered on.
6. After the charging process, disconnect the battery charger from the mains supply. First remove the clamp from the negative terminal, then from the positive terminal.



NOTE: READ ALL INSTRUCTIONS AND WARNINGS CAREFULLY BEFORE USE.

PRODUCT SAFETY

- Only to be used to charge 6V/12V lead-acid wet cell, gel, AGM and Calcium batteries.
- Do not expose charger to rain or snow.
- Use of an attachment not recommended or sold by the battery charger manufacturer may result in a risk of fire, electric shock, or injury to persons.
- To reduce risk of damage to electric plug and cord, pull by plug rather than cord when disconnecting the charger.
- Make sure cord is located so that it will not be stepped on, tripped over, or otherwise subjected to damage or stress.
- When using this charger with an extension lead ensure the cord has the same number, size and shape pins as the charger and that the cord is properly wired and in good condition
- If the charger or leads appear damaged, do not operate the charger.
- Disassembling the charger will result in loss of warranty and may increase the risk of electric shock or fire.
- When inspecting or cleaning the unit/battery connected to the charger, ensure that the charger is disconnected from 240V power.
- Batteries contain explosive gases. Before charging or using your battery, it's important you read your battery's user manual.
- Using the incorrect charging setting can be harmful to your battery and may reduce the lifespan of your battery as a result. Use only the recommended charging setting for your battery.
- SLA batteries displaying a a charge of 3V for an extended period of time while charging should be replaced. This indicates that the charger is not able to increase the battery's voltage.

PERSONAL SAFETY

- Someone should be within range of your voice or close enough to come to your aid when you work near a lead-acid battery.
- Have plenty of fresh water and soap nearby in case battery acid contacts skin, clothing, or eyes.
- When working around batteries, it's recommended you've got soap and fresh water available in case you come in contact with battery acid.
- If battery acid comes in contact with your eyes, flush the affected eye with cold running water for 10 minutes and seek medical attention.
- Batteries should never be operated around flames or spark.
- Metals can cause a battery to spark or short circuit when they come in contact with the battery terminals. Exercise caution when using tools or metal objects around the battery.
- Using this charger with batteries not prescribed within this manual may result in personal injury or damaged property.
- Batteries should never be charged when cold or frozen.

BATTERY SAFETY

- Ensure your battery is always fitted securely
- A perfect connection to the cable network of the electrical system must be ensured at all times
- Keep the battery clean and dry. Apply a thin coating of grease to the connection terminals using an acid-free, acid-resistant grease (Vaseline).
- Check the level of acid in the batteries that are not maintenance-free versions approx. every 4 weeks and top up with distilled water accordingly.
- Charging lithium batteries in cold climates can permanently damage the cells and reduce the lifespan of the battery. Lithium batteries should never be charged in conditions below 0° unless they are equipped with a cold climate function. Refer to your battery's user manual.

TROUBLESHOOTING

Error Code: **ERR**

Condition: Charge does not begin

Possible cause: The battery clamps are connected with reverse polarity.	Solution: Disconnect and reconnect the battery clamps in order.
---	---

Possible cause: The battery voltage is not matched with the selected mode.	Solution: Confirm that battery voltage is matched with the battery mode.
--	--

Error Code: **BAD**

Condition: Charge does not begin

Possible cause: The battery is defective.	Solution: Replace the battery.
---	--

Condition: Charge voltage too low

Possible cause: The battery is deep-discharged.	Solution: Charge over 12 hours first. If the battery is back to normal voltage, it has regenerated.
---	---

Condition: Battery not fully charged after 24 hours charge time.

Possible cause: The charge current is too low.	Solution: Select a higher charge rate.
--	--

Condition: The battery voltage rises quickly

Possible cause: The charge current is too high.	Solution: Select a lower charge rate.
---	---

WARRANTY POLICY

Our goods come with guarantees that cannot be excluded under the Australian Consumer Law. You are entitled to a replacement or refund for a major failure and compensation for any other reasonably foreseeable loss or damage. You are also entitled to have the goods repaired or replaced if the goods fail to be of acceptable quality and the failure does not amount to a major failure.

Hardkorr warrants that this product will be free from defects in material and workmanship for two years. The warranty commences on the date of purchase by the original purchaser, and is not transferable. To access the benefits of this warranty, you must retain your proof of purchase and follow any other direction we reasonably give you (e.g. completing and returning your warranty card if applicable).

If you believe your Hardkorr product is defective, it must be returned to Hardkorr for inspection by our warranty claims department. Hardkorr will not be liable for any charges you incur relating to installation, repair or removal of Hardkorr products, nor for any costs incurred in returning the product to us.

To make your warranty claim:

1. You must first obtain a Return Authorization (RA) number. To get your RA number, please complete the form found on our website and wait for the warranty team to contact you.
2. Once you have an RA number, you must arrange for the product must be shipped back to Hardkorr (except in the case of fridge/freezers, which must be taken to an authorised service agent for examination).
3. Please include a copy of your original proof of purchase.
4. Please be sure that your RA number is clearly marked on your documentation as well as on the outside of the packaging used for shipping.

Completing the steps above will ensure faster processing of your claim, so that Hardkorr can get your product back to you as soon as possible.

If Hardkorr determines, at our sole discretion, that your product is defective in material or workmanship, we will honor your warranty claim. We will determine whether the item is repaired or replaced.

Your warranty is voided if we determine (at our sole discretion) that there is evidence of any of the following:

Negligence: Improper installation, improper or extreme use, etc.

Abuse: Road hazards, Damage beyond the limits of "normal wear and tear".

Unauthorized Repair: Repair service performed by an unauthorized service centre.

Disassembly: Any attempt to open, tamper with or otherwise compromise the integrity of the product.

Discontinued Items: Discontinued items that are still under warranty will be reviewed by Hardkorr. If a discontinued item is covered under warranty it may be replaced by an equivalent item. If an equivalent item is not available Hardkorr will determine terms of resolution on a case-by-case basis.

Exceptions to this Warranty:

Painted Finish: Hardkorr uses the highest quality materials available, but depending on location, environment and exposure, painted surfaces can fade. We will not approve any warranty claims that relate to faded paint.

Damage to Lenses: Please be aware that certain chemicals cause damage to polycarbonate plastics. Do not use cleaning products that contain any chemicals in the following list:

Acetic Acid Aq., Acetone, Ammonium Carbonate Aq., Ammonium Chloride Aq., Benzene, Calcium Hypochlorite, Chloroform, Chromic Acid Aq., Ethyl Acetate, Ethylene, Glycol Aq., Formaldehyde Aq., Citric Acid, Heptane, Hydrofluoric Acid Aq., Lubricating Oils (Petroleum), Methyl Ethyl Ketone, Methyl Chloride, Mineral Oils, Oleic Acid, Ozone, Phosphoric Acid Aq., Toluene, Turpentine, Zinc Chloride Aq.

Hardkorr will not approve any warranty claims for lighting products where we reasonably believe that products have been exposed to any of these chemicals.



HARDKORR

www.hardkorr.com