



Sphere Touch Control Rangehood



Model No. TCR-001

Please read and save the instruction



Sphere Touch Control Rangehood



Features:

- ❖ Touch Control Tempered Glass Front
- ❖ Variable Speed
- ❖ 2 High Volume Airflow 12v Fans
- ❖ Built In Clock
- ❖ LED Stripe Light
- ❖ Removable Easy to Clean Filter
- ❖ Stainless Steel Construction
- ❖ Vents through the Rear or Top
- ❖ Easy to Fit
- ❖ W 530mm x D 304mm x H 60mm

SPECIFICATIONS:

Power	12 volt
Rating Motor input Power: Maximum	2 x16W
Illumination: Maximum	3W
Total input Power	35W
Air Flow	100 m3/hr
Removable Filter	5 layer Aluminium mesh
Out Side Dimension	W 530mm x D 304mm x H 60mm
Body Material	Stainless Steel

INSTALLATION:

Note:

When installing Rangehood into a Recreational Vehicle, ensure that it is fitted in accordance to all Australian Standard requirements

The Sphere touch control Rangehood can be installed using 2 different methods.

Option 1. Top Mounting

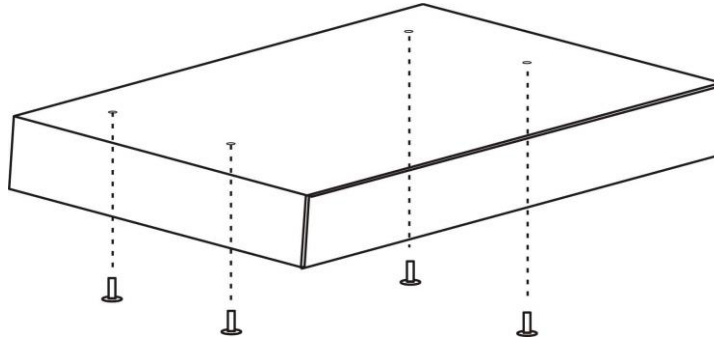

Steps: (Hole cut out made to the specified sizing)

1. Remove filter to access to pre punched screw locating holes in the top of the Rangehood
2. Connect wires to the 12volt power source (Wires labelled +/- please ensure wires are connected the correct way)
3. Lift Rangehood into designated position
4. Mount using 4 only SS screws into pre punched locating holes (Shown above)
5. Install filter
6. Test Rangehood and ensure unit is working correctly

Option 2. Side Mounting

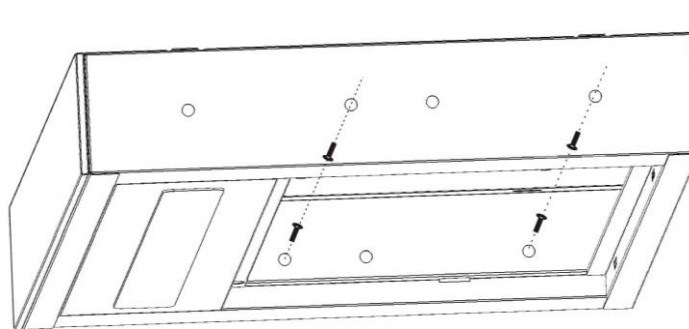

Steps: (Hole cut out made to the specified sizing)

1. Remove filter to access to pre punched screw locating holes in the top of the Rangehood
2. Connect wires to the 12volt power source (Wires labelled +/- please ensure wires are connected the correct way)
3. Lift Rangehood into designated position
4. Mount using 4 only SS screws into pre punched locating holes (Shown Above)
5. Install filter
6. Test Rangehood and ensure unit is working correctly

PART NAMES:

1. Tempered glass
2. Switch
3. Switch box
4. Left panel
5. Right panel
6. PCB box base
7. Vent duct plate
8. Air flu
9. Air housing
10. PCB
11. PCB box
12. Filter
13. Light panel
14. Light cover
15. LED Light

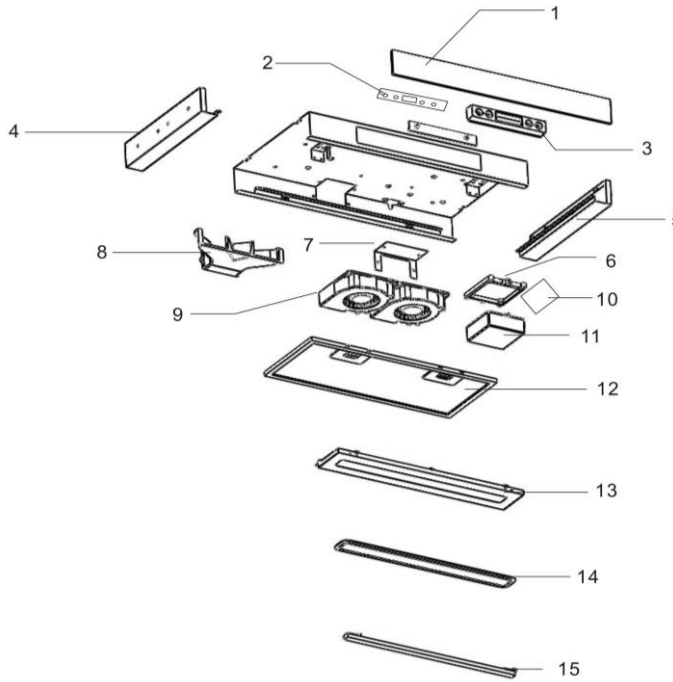

CONTROL PANEL OPERATION:

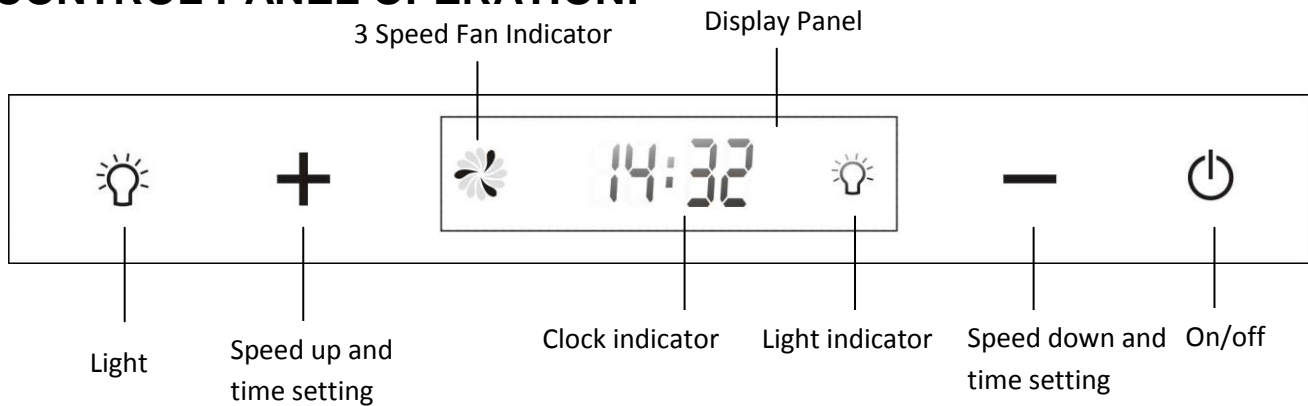







 : Control the light on and off

 : Speed up and time setting

 : Speed down and time setting

 : Power on/off

How to set the clock:

When the hood is on standby status, Press the key  for 3 seconds to enter the clock setting, the Clock indicator are flicking, press the key  or  to set the hour. Then press again the key  move to the minute setting, press  or  to set the minute. The machine will automatically confirm if without any operation in 3 seconds.

Note: Each time the rangehood connects to the power supply, the clock indicator just show 00:00.

CLEANING AND CARE:

1. Turn off the Rangehood before cleaning

2. Remove filter

- a. Wash using warm water and a Mild detergent
- b. Using a **NON** abrasive cloth
- c. Allow to dry before refitting clean filter

3. Clean all viewable surfaces

- a. Wash using warm water and a Mild detergent
- b. Using a **NON** abrasive cloth

Note: Do not clean electrical components with water or a wet cloth.

WARRANTY:

IF YOU HAVE A PRODUCT PROBLEM:

First:

If your Sphere TCR-001 Rangehood is factory fitted as part of your NEW RV, Please Contact the OEM Manufacture of the RV or refer to the OEM RV User and Warranty handbook for further information.

Second:

Service Contact:

Coast RV Pty Ltd

trading as Coast to Coast RV Services
ABN 49 097 104 492 - ACN 101 461 330
PO Box 415, Regents Park NSW 2143

AUSTRALIA

Ph (02) 9645 7600 - Fax (02) 9645 7699
Email: warranty@coastrv.com.au
Web: www.coastrv.com.au

Coast to Coast RV Services
PO Box 58-054, Botany AUCKLAND 2163

NEW ZEALAND

Ph (09) 274 8700 – Fax (09) 274 8701
Email: enquiry@coastrv.co.nz
Web: www.coastrv.co.nz

Warranty Against Defects

1 WHAT THIS WARRANTY RELATES TO

- 1.1 This warranty covers goods supplied by Coast RV Pty Ltd T/A Coast to Coast RV Services ("Supplier") to the Client ("Goods") and relates to any defects in materials and workmanship under normal use and maintenance ("Defect").

2 WHAT THE SUPPLIER WILL DO TO HONOUR THE WARRANTY

- 2.1 The Supplier will:

- (i) replace or repair the Goods or the defective part of the Goods free of charge;
- (ii) arrange for the Goods or the defective part of the Goods to be repaired or replaced by a qualified repairer free of charge.

- 2.2 The Supplier reserves the right to replace defective parts of the Goods with parts and components of similar quality, grade or composition where an identical part or component is not available.

- 2.3 Goods presented for repair may be replaced by refurbished goods of the same type rather than being repaired. Refurbished parts may be used to repair the goods.

3 WHAT THE CLIENT MUST DO TO CLAIM THE WARRANTY

- 3.1 To claim the benefit of the warranty, the Client will need to (sequentially):

- (i) first contact the Supplier; and
- (ii) present the defective Goods to the Supplier for inspection, including inspection for defective workmanship, or otherwise provide evidence of the claimed Defect, accompanied by evidence of proof of purchase and date of delivery, and if applicable, evidence of maintenance performed in accordance with the relevant maintenance schedules.

- 3.2 The claim listed in clause 3.1 may be made in person, or the claim may be sent to the address listed on this form, including the particulars required under clauses 3.1(i) and 3.1(ii).

- 3.3 The appropriate form for making a claim for warranty is as attached.

4 DURATION OF WARRANTY

- 4.1 This warranty will cease:

- (i) where the Goods are purchased already fitted in or as a component of a vehicle or RV: from the date that is twelve (12) months after the Client takes delivery of the vehicle or RV; and
- (ii) where the Goods are purchased separately or as an after-market item: from the date that is twelve (12) months from the date of purchase..

- 4.2 If a Defect does not materialise in the Goods prior to the date provided in clause 4.1, the Supplier will have no liability to the Client under this warranty.

5 RESPONSIBILITY FOR COSTS OF CLAIM UNDER THIS WARRANTY

- 5.1 The Supplier is responsible for the costs directly associated with repairing or replacing the Goods in accordance with clause 2.1 only.

- 5.2 Any works required to be completed in addition to fixing the Defect are the responsibility of the Client. Additional works includes any costs associated with any testing or repair of the Goods or any goods to which they are fitted, undertaken by a third party in relation to any defect without prior authorisation from the Supplier.

- 5.3 Where it is determined that the Goods do not have a Defect, the Client will be charged a GST exclusive inspection fee of forty-five dollars (\$45.00AUD in Australia or \$45.00NZD in New Zealand) plus freight costs for the return of the Goods, this is subject to change without notice.

- 5.4 The cost of delivery and insurance of the Goods to and from the Supplier, travel costs to and from the Supplier, and the cost of inspecting and testing the Goods are the sole responsibility of the Client.

6 WARRANTY LIMITATIONS

- 6.1 The Supplier makes no warranties or representations other than those set out in this warranty document except as is required by law.
- 6.2 The Supplier will not be liable under this warranty:-
- (i) to the Client or any other person for any consequential, direct or indirect loss, damage or costs incurred or suffered by the Client or any other person, including but not limited to damage to persons, other property, loss of turnover, loss of profits, loss of business or goodwill;
 - (ii) to the Client for transportation or travel costs which are the Client's responsibility;
 - (iii) for damage or defects in any Goods caused by improper transportation, storage or any other misuse, neglect or accident.
 - (iv) for the installation of the Goods. Any fault or defect due to installation should be referred to the installer. The Goods must be installed in accordance with the Manufacturer's instructions and any relevant legislation or code.
- 6.3 This warranty covers the Client only and it is not transferrable if the Goods are sold by the Client during the warranty period.

7 WARRANTY EXCLUSIONS

- 7.1 This warranty will not apply where:
- (i) the Goods have been improperly modified or repaired or the Good's defect has arisen due to the Client's failure to properly install, fit, maintain, service or use the Goods in accordance with the specifications and instructions provided by the Manufacturer, including a failure to comply with the relevant maintenance schedule (where applicable);
 - (ii) the Supplier cannot establish any Defect in the Goods after testing;
 - (iii) the Goods have been used other than for the purpose for which they were designed;
 - (iv) the Goods have been subject to abnormal conditions, including but not limited to temperature, pressure, stress, load or similar;
 - (v) the Client or installer have used or fitted non-genuine or non-approved parts and accessories to the Goods or have failed to use recommended parts and accessories;
 - (vi) the Good's defect has arisen due to abuse, misuse, neglect or accident;
 - (vii) the Goods have not been installed in accordance with the relevant instructions;
 - (viii) the Good's defect is caused by use or fair wear and tear of the Goods (or expendable parts).

8 RIGHTS AT LAW

- 8.1 The benefits given to the Client under this warranty are in addition to other rights and remedies of the Client at law in relation to the Goods.
- 8.2 In Australia our Goods come with guarantees that cannot be excluded under the Australian Consumer Law. You are entitled to a replacement or refund for a major failure and for compensation for any other reasonably foreseeable loss or damage. You are also entitled to have the Goods repaired or replaced if the Goods fail to be of acceptable quality and the failure does not amount to a major failure.

WARRANTY CLAIM FORM

Warranty Providers Name:

Coast RV Pty Ltd trading as Coast to Coast RV Services
ABN 49 097 104 492 - ACN 101 461 330

Warranty Providers Address:

PO Box 415 Regents Park NSW 2143 Australia OR;
PO Box 58-054 Botany AUCKLAND 2163 New Zealand

Client:

Contact No.

Description of Goods provided:

Receipt enclosed: *(tick box)*

Yes

No

Receipt No:

Description of defects (Give as much detail as possible. Use a separate page if required):

Date of purchase/services provided:

I hereby declare that the information provided above is true and correct and to the best of my knowledge and belief and I have complied with all the conditions of the warranty.

Signed:.....

Name:
(please print)

Dated:

[Please note, the issue or completion of this form by the Client does not constitute an admission of liability by the Supplier]