

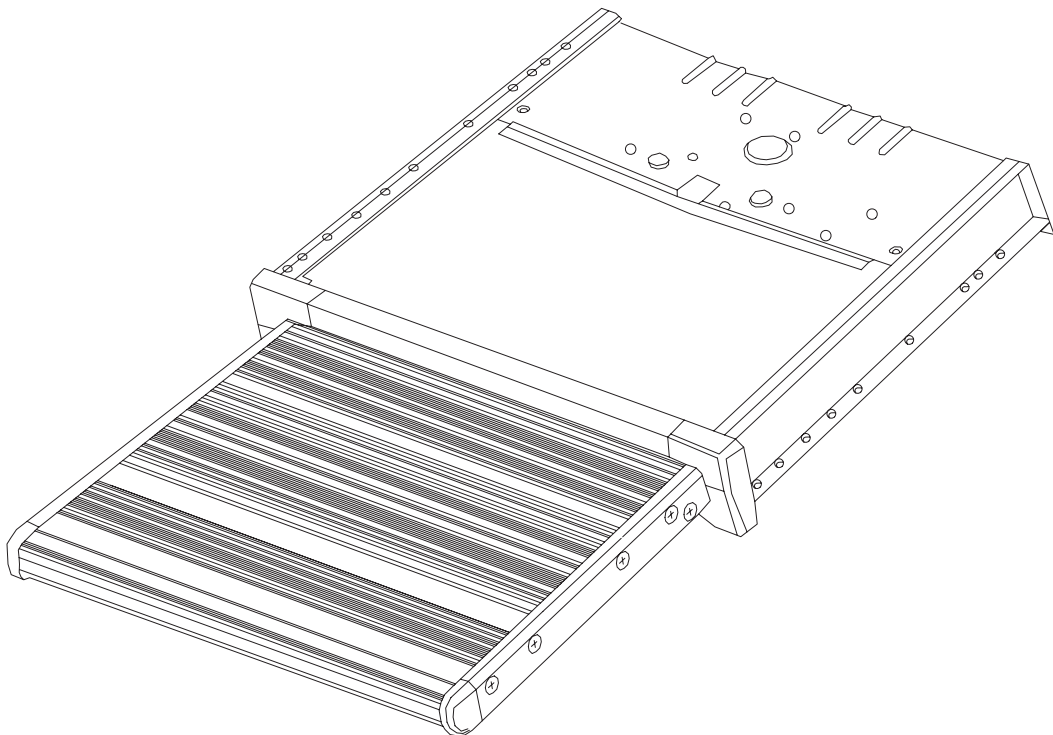

SLIDE OUT 12V & MANUAL STEPS

INSTALLATION MANUAL





Read this installation instruction thoroughly.
Incorrect installation or operation may void any warranty.
Incorrect use or operation may cause serious injury.

PRODUCT INTRODUCTION

The Aussie Traveller range of Slide Out 12V and Manual steps are designed to be used as high-quality equipment which can help passengers get into a full range of Recreational Vehicles, including Caravans, Campers, Motorhomes and Emergency Vehicles.

Ask Aussie Traveller about the full range of RV steps available.

DESCRIPTION:

- Aussie Traveller Slide Out steps offer a range of widths to suit many sizes of Recreational Vehicles and Emergency Vehicles.
- Easy to install, available in 400mm, 550mm and 700mm width sizes.

MODEL	CURRENT DRAW	PLATFORM SIZE (L×W)	WEIGHT
400mm Step	Idle —5 Amp Fully Extending or Retracting —12–16 Amp	405×295mm	5.6kg
550mm Step	Idle —5 Amp Fully Extending or Retracting —12–16 Amp	550×295mm	6.5kg
700mm Step	Idle —5 Amp Fully Extending or Retracting —12–16 Amp	750×295mm	7.4kg

STANDARD PACKING LIST:

- 1 × Slide Step
- 1 × Mounting Kit

Includes:

- 4 × M8x50 Hex Bolts
- 4 × M8 Washers
- 4 × M8 Safety Nuts
- 1 × In/Out Switch
- 1 × Switch Cover Plate
- 6 × Flat Connectors

- 1 × User Manual

1300 663 868 | enquiries@aussietraveller.com.au | aussietraveller.com.au

BRISBANE SHOWROOM: 11-15 Oasis Court, Clontarf QLD 4019 | MELBOURNE SHOWROOM: 235 Barry Road, Campbellfield VIC 3061



INSTALLATION

REQUIREMENTS:

Please refer to ADR58 / EN 1645-1 (caravans) requirements, for correct installation of an RV Manual or Electric step.

INSTALLATION OF THE AUSSIE TRAVELLER SLIDE STEP:

It is recommended that the installation instructions are followed. Depending on the vehicle type, the installation requirements may vary. Various mounting attachments / installations are listed below:

- Right through the vehicle bottom/footwell.
- In rails incorporated in the chassis.
- In a special construction welded or bolted to the chassis.

NOTE: Depending on the specific installation, position of the steps and specific installation process may change.

1. Prior to installation, extend the step by connecting the 12V DC to the step motor.
2. Temporarily connect the **Blue** wire to the motor **positive** and the **Red** wire to the motor **negative**. Allow the step to fully extend.
3. Remove the wires from the step motor once step is fully extended.
DO NOT LEAVE POWER TO THE MOTOR ONCE FULLY EXTENDED – REMOVE BEFORE 3 SECONDS.
4. Using the dimensional diagrams, drill 4 holes of 9mm diameter to the base/chassis location for the step to be mounted. When the step is fully retracted, the step will protrude 60mm from the frame.
5. Make sure the step is correctly positioned, install the step and tighten the bolts, washers and nuts.
6. Check the operation of the step - Retract the installed step by connecting the 12V DC to the step motor. Temporarily connect the **Blue** wire to the motor **negative** and the **Red** wire to the motor **positive**. Allow the step to fully retract.

INSTALLATION OF THE AUSSIE TRAVELLER STEP SWITCH:

Install the step switch in a convenient location, recommended to be close to the entrance door or main door to the cabin area.

1. Drill a 48mm diameter hole in the wall location.
2. Mount the cover plate using 4 × 2.9×9.5mm screws.
3. Run the electrical cable (2×2.5mm²) from the battery to the rear of the switch via a 16 Amp fuse in the **positive (+)** conduction.
(**Recommended** – to avoid short circuit, before introducing the fuse, ensure the electrical connection is complete.)
4. Run the motor wires from the step motor to the in/out switch.
5. Connect the wires to the Flat Connectors provided before connecting to the in/out switch.
6. Ensure wires are connected as per wiring diagram.
7. Connect the fuse into the fuse holder and the operate the step.
8. Installing the wrong fuse can cause cable fire in case of a short circuit or malfunction.

1300 663 868 | enquiries@aussietraveller.com.au | aussietraveller.com.au

BRISBANE SHOWROOM: 11-15 Oasis Court, Clontarf QLD 4019 | MELBOURNE SHOWROOM: 235 Barry Road, Campbellfield VIC 3061

WIRING DIAGRAM

PIN & WIRING LOCATIONS

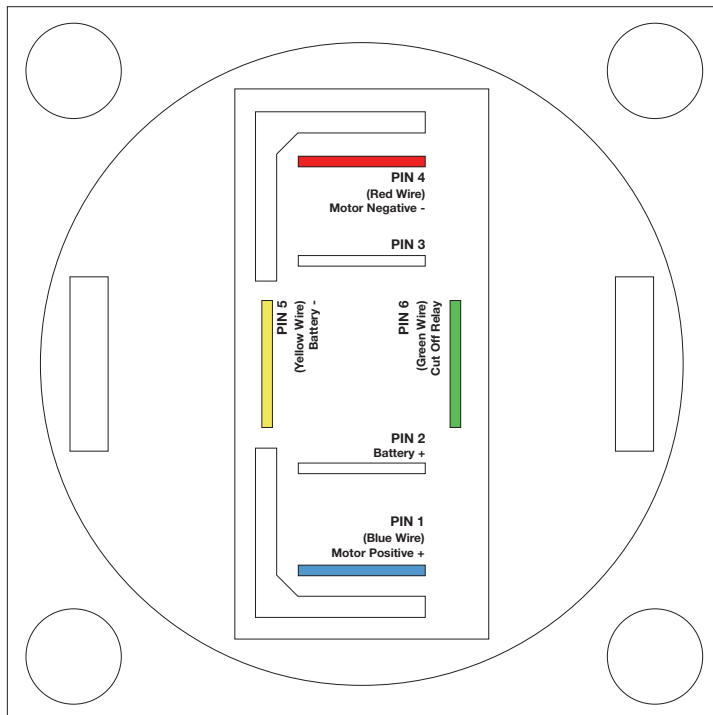

AT DROP DOWN 12V STEP PIN AND WIRING LOCATIONS

Blue Wire: Motor Positive PIN 1
 Yellow Wire: Battery Negative PIN 5
 Green Wire: Connect to PIN 6
 Red Wire: Connect to PIN 4

***YELLOW WIRE TO BE CONNETED
 (SPLICED) TO BATTERY NEGATIVE**

SWITCH WIRING DIAGRAM

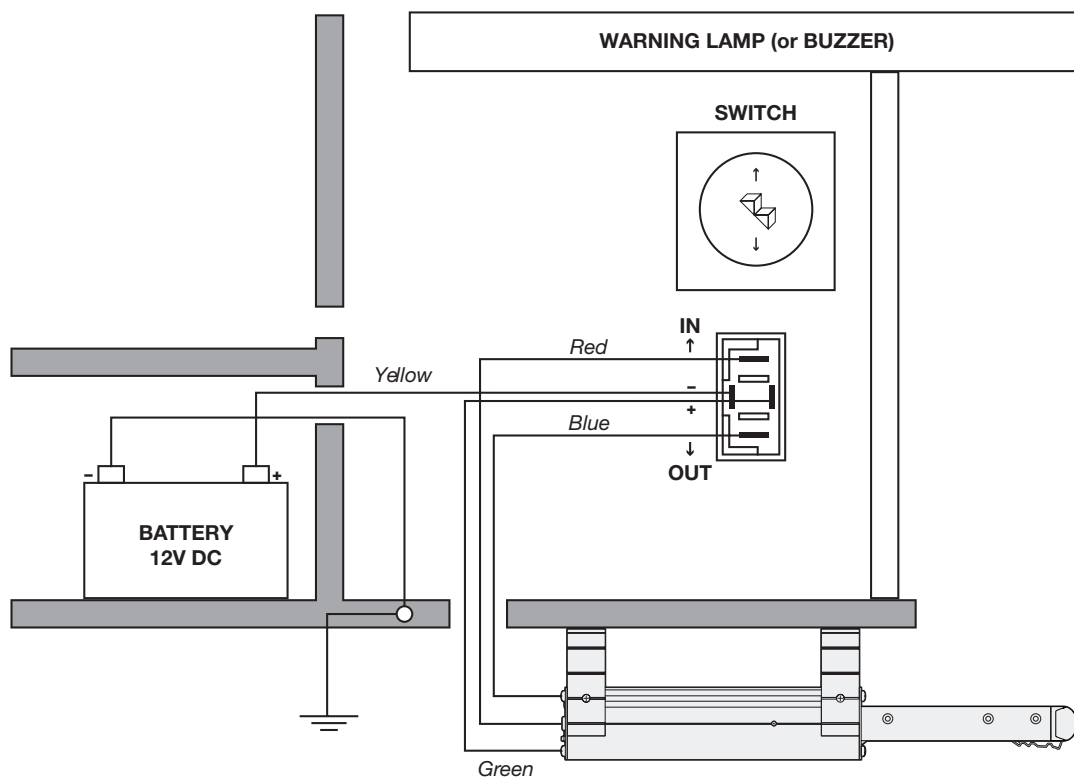

1300 663 868 | enquiries@aussietraveller.com.au | aussietraveller.com.au

BRISBANE SHOWROOM: 11-15 Oasis Court, Clontarf QLD 4019 | MELBOURNE SHOWROOM: 235 Barry Road, Campbellfield VIC 3061

OPERATING THE 12V SLIDE OUT STEP

The Aussie Traveller 12 Volt Slide Out step is operated by the supplied in/out switch, mounted as per the installation instructions.

IMPORTANT:

When operating the step, hold the switch in the OUT position until the step is completely extended.

- Never use the step unless the vehicle is in a secure, stationary position.
- Ensure the step is fully retracted before the vehicle is to depart.



NEVER STEP ON TO THE FOOTBOARDS IF THE STEP IS IN OPERATION, NOT FULLY EXTENDED OR IS RETRACTED. THIS COULD CAUSE INJURY AND FAILURE OF THE STEP.

OPERATING THE MANUAL SLIDE OUT STEP

When operating the Aussie Traveller Slide Out Step once installed.:

- To open, firmly grasp the front of the foot plate, push up slightly and pull the step out to full extension. When at full extension, release the foot plate.
- To close, firmly grasp the front of the foot plate, push up slightly and push the step in to full close position. When at full close, release the foot plate.

IMPORTANT:

- Do not operate the step when the foot plate is not either in the **FULLY CLOSED** or **FULLY OPEN** position.

MAINTENANCE:

Dirt, dust, water and frost can prevent the step from operating correctly. Ensure that step is cleaned regularly and dried if water is used. Never use harsh chemicals or brushes to clean the step.

NOTE: Regular maintenance required.

1300 663 868 | enquiries@aussietraveller.com.au | aussietraveller.com.au

BRISBANE SHOWROOM: 11-15 Oasis Court, Clontarf QLD 4019 | MELBOURNE SHOWROOM: 235 Barry Road, Campbellfield VIC 3061

MANUAL RELEASE

IN CASE OF MOTOR OR ELECTRICAL FAILURE:

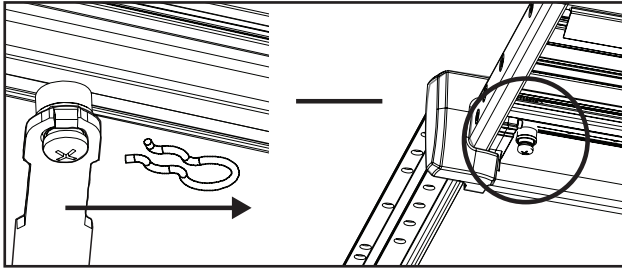

1. With power turned off, remove the 2× circlips under the foot plate connected to the slide step arms.

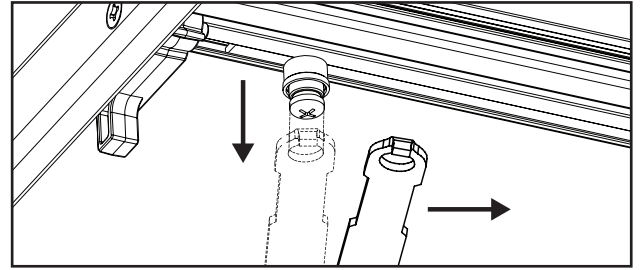

2. Pull the arms **DOWN** off the bolt and shaft connected to the foot plate. Push circlips back on to the bolt or store in a safe location.

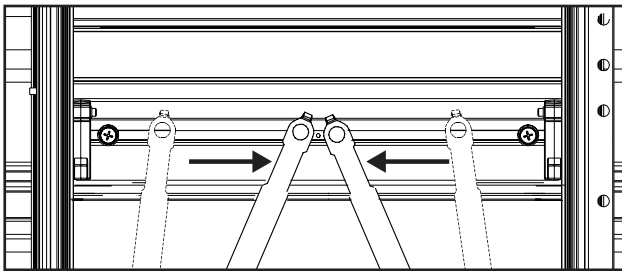

3. Move the arms towards the centre of the footplate.

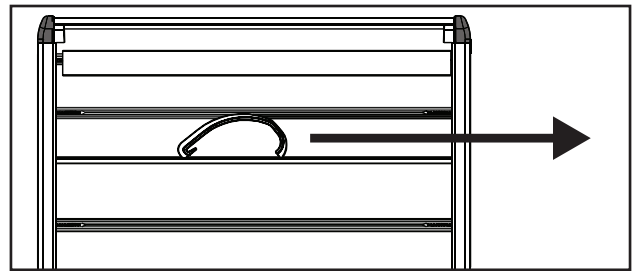

4. Underneath the main body of the slide step, remove the large plastic holding clip.

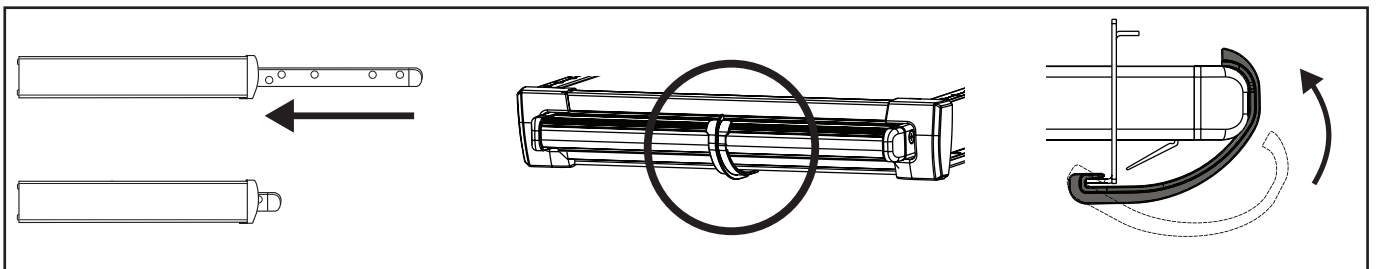

5. Push the foot plate in until fully retracted (**Closed**) and secure the plastic holding clip to the top of the step and then wrap the plastic holding clip to the underneath fascia of the step body.

1300 663 868 | enquiries@aussietraveller.com.au | aussietraveller.com.au

BRISBANE SHOWROOM: 11-15 Oasis Court, Clontarf QLD 4019 | MELBOURNE SHOWROOM: 235 Barry Road, Campbellfield VIC 3061

TECHNICAL PARAMETERS - 400MM SLIDE OUT STEP

12V PART NUMBER: 40700010001000

MANUAL PART NUMBER: 40700000001000

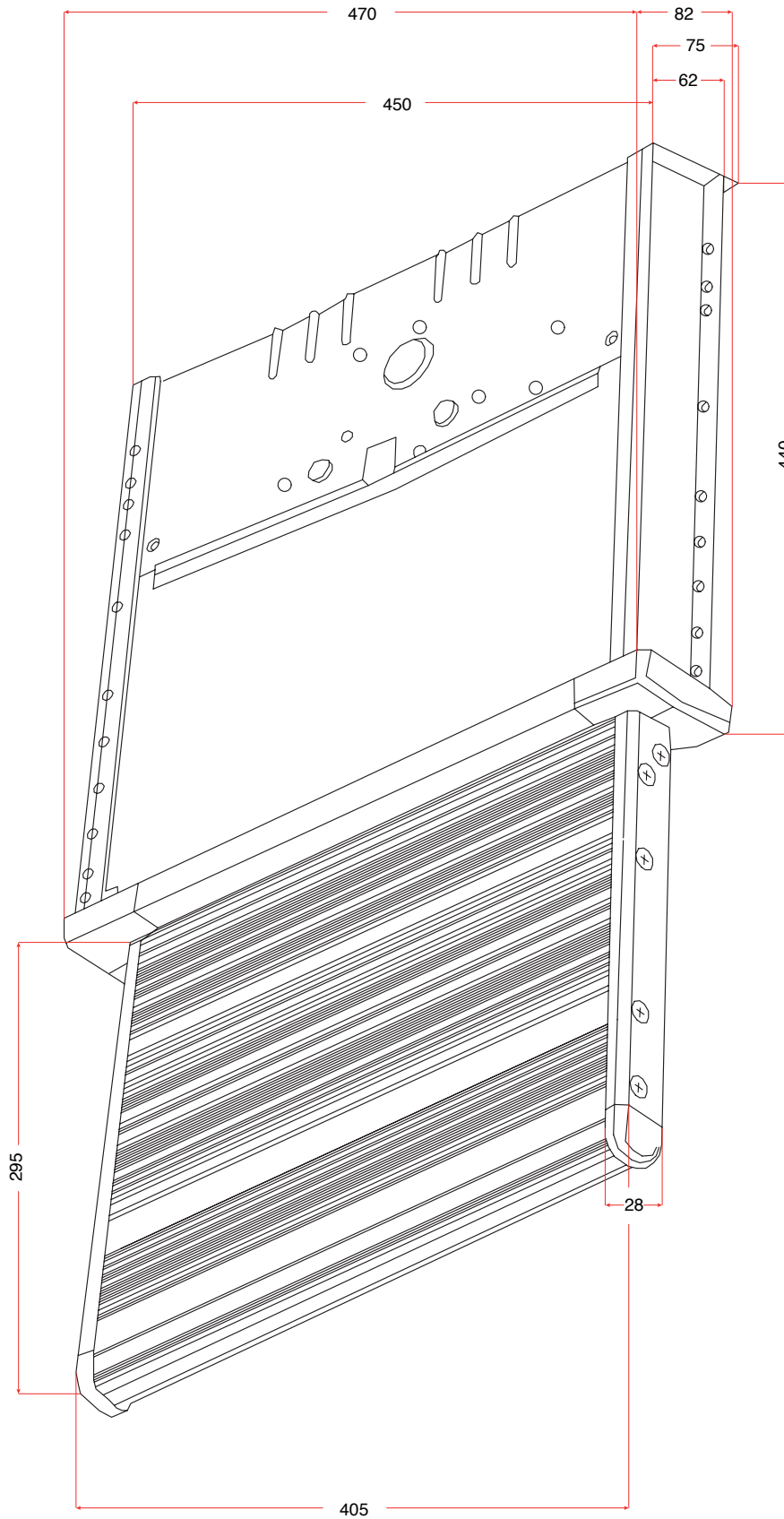

1300 663 868 | enquiries@aussietraveller.com.au | aussietraveller.com.au

BRISBANE SHOWROOM: 11-15 Oasis Court, Clontarf QLD 4019 | MELBOURNE SHOWROOM: 235 Barry Road, Campbellfield VIC 3061

TECHNICAL PARAMETERS - 550MM SLIDE OUT STEP

12V PART NUMBER: 40600000004000

MANUAL PART NUMBER: 40600000003000

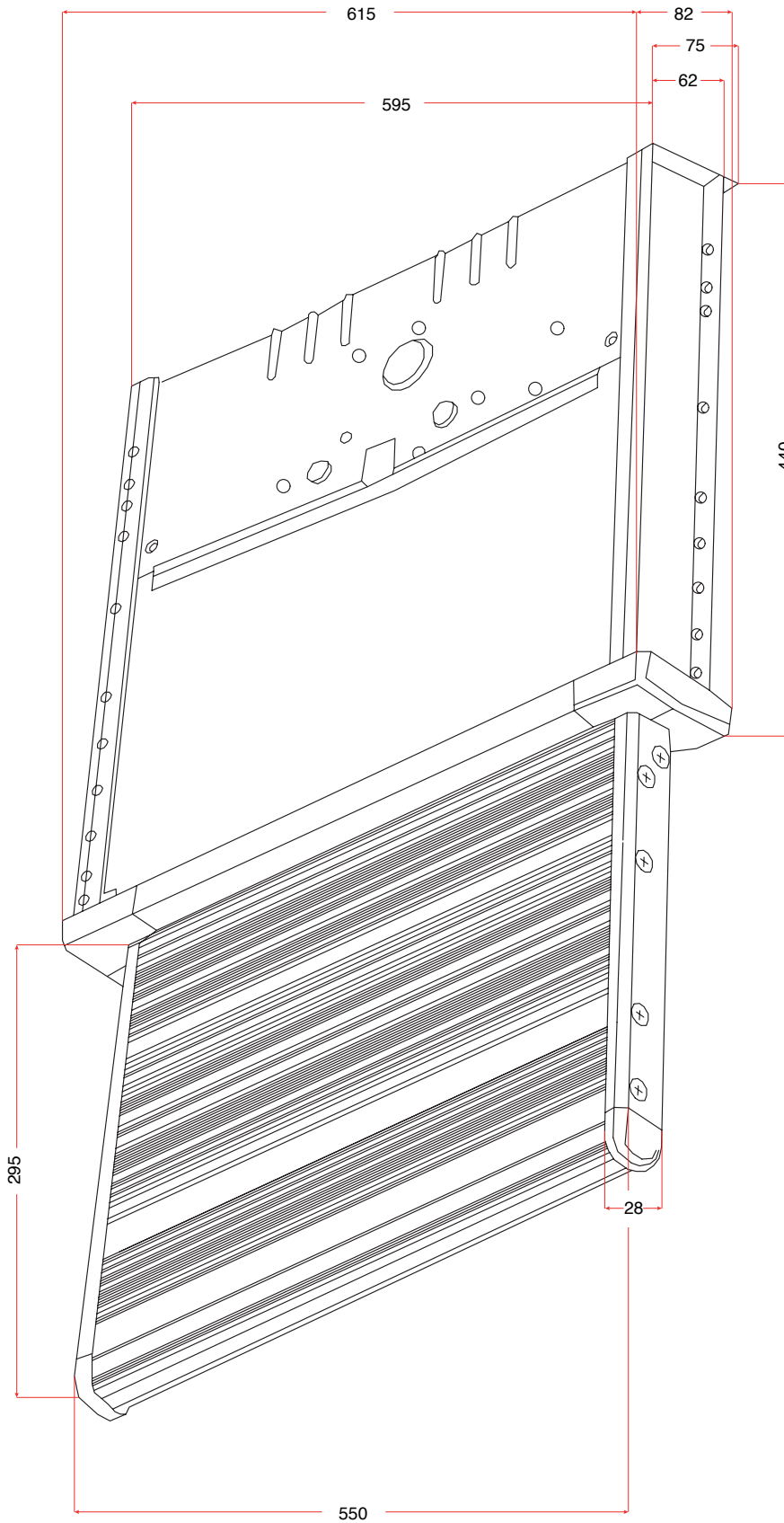

1300 663 868 | enquiries@aussietraveller.com.au | aussietraveller.com.au

BRISBANE SHOWROOM: 11-15 Oasis Court, Clontarf QLD 4019 | MELBOURNE SHOWROOM: 235 Barry Road, Campbellfield VIC 3061

TECHNICAL PARAMETERS - 700MM SLIDE OUT STEP

12V PART NUMBER: 40700000002000

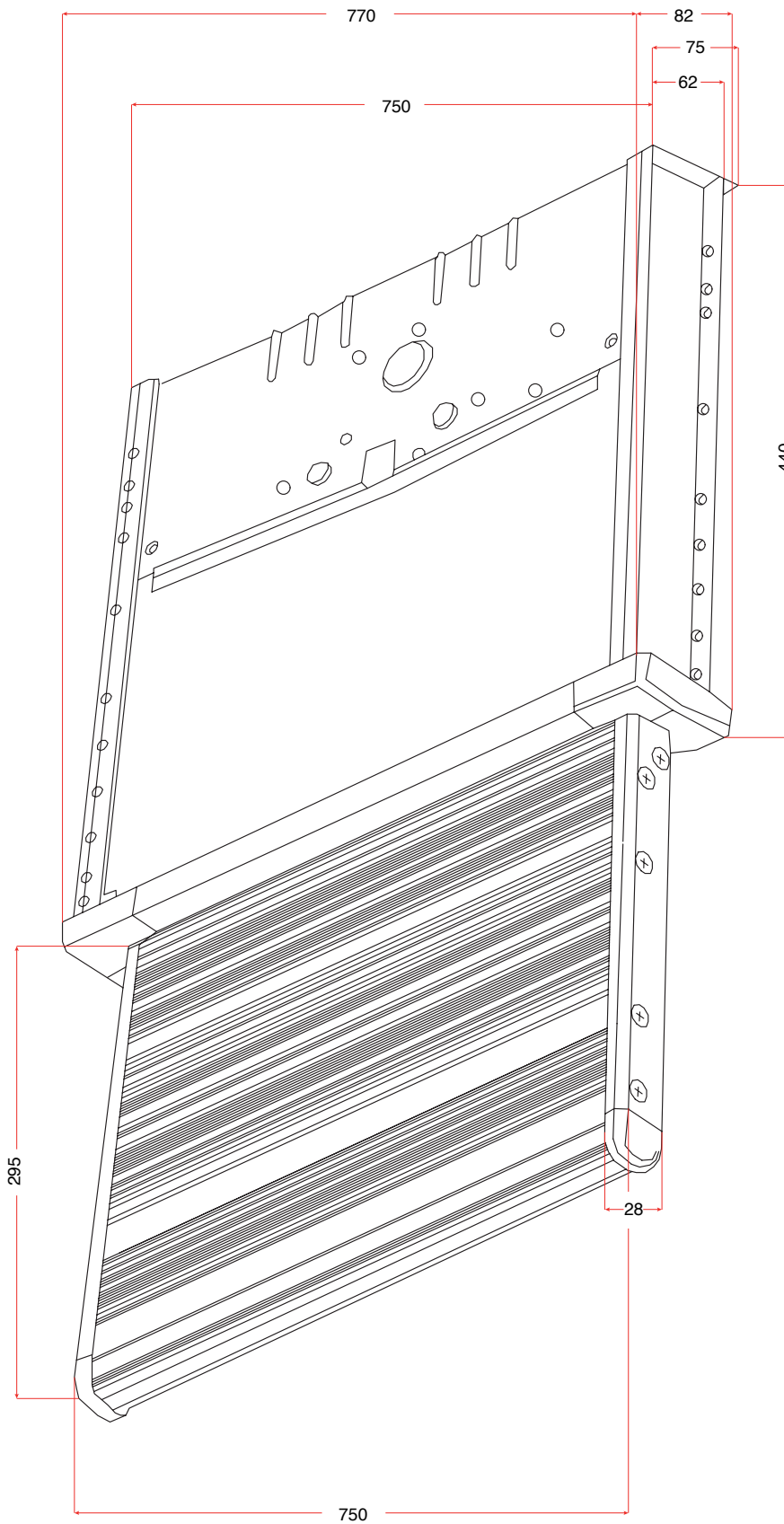

1300 663 868 | enquiries@aussietraveller.com.au | aussietraveller.com.au

BRISBANE SHOWROOM: 11-15 Oasis Court, Clontarf QLD 4019 | MELBOURNE SHOWROOM: 235 Barry Road, Campbellfield VIC 3061

WARRANTY STATEMENT

Aussie Traveller Pty Ltd ACN 642 775 460 (**Aussie Traveller**) offers the following warranty in relation to the products it supplies directly or through an authorised manufacturer, dealer or approved service repair agent (**Product**).

Australian Consumer Law

The benefits of this warranty are in addition to any rights and remedies imposed by Australian State and Federal legislation that cannot be excluded. Nothing in this warranty is to be interpreted as excluding, restricting or modifying any State or Federal legislation applicable to the supply of goods and services which cannot be excluded, restricted or modified.

If you are a consumer as defined in the Australian Consumer Law: *Our goods come with guarantees that cannot be excluded under the Australian Consumer Law. You are entitled to a replacement or refund for a major failure and compensation for any other reasonably foreseeable loss or damage. You are also entitled to have the goods repaired or replaced if the goods fail to be of acceptable quality and the failure does not amount to a major failure.*

Warranty

Aussie Traveller warrants that, subject to the exclusions and limitations below, all parts of the manufacture and assembly of the Product will be free from defects in materials and workmanship (**Warranty**) for a period of 12 months from the date of purchase as follows:

1. This Warranty is activated at the time of purchase by the final retail customer (being the owner of the Product).
2. In the event the Product is purchased by a manufacturer, dealer or approved service repair agent, this Warranty will commence at the time the final retail customer makes payment for the Product to the wholesale purchaser.
3. If the Product is purchased directly from Aussie Traveller for use by final retail customer and not to be on sold in any way, the Warranty will commence at the time of the original purchase.

Warranty Period

This Warranty cannot be assigned or transferred to a subsequent owner of the Product.

The purchaser or final retail customer should inspect the Product immediately when received or at vehicle handover, to ensure that it appears free from any damage or defect, and matches the description provided.

If after accepting the Product, a defect appears in the manufacture or assembly of the Product before the end of the Warranty Period and Aussie Traveller finds the Product to be defective in materials or workmanship, Aussie Traveller will, in its sole discretion, either:

- a. replace, repair or refund the Product or the defective part of the Product free of charge; or
- b. cause the Product or the defective part of the Product to be replaced or repaired by a qualified repairer free of charge.

In arranging Warranty inspection, service and repair, Aussie Traveller will seek to provide the details of an approved service agent within your geographic area. Should one not be available, or if the Product is in use in travel, Aussie Traveller reserves the right to seek to arrange a repair or replacement at the next available location on the route of travel.

Aussie Traveller reserves the right to replace defective parts of the Product with parts and components of similar quality, grade and composition where an identical part or component is not available.

Products presented for repair may be replaced by refurbished goods of the same type rather than being repaired. Refurbished parts may be used to repair the Product.

Aussie Traveller Awning Products

This Warranty covers specified defects in materials or workmanship for Awning Products as follows:

1. The vinyl fabric is warranted against:
 - a. holes caused by mildew (mildew will form on dust and dirt and stain fabric if fabric is not kept clean).
 - b. excessive cracking, peeling, hardening or loss of strength while used under normal conditions.
 - c. excessive fading (a slight colour change may occur due to ultraviolet rays).
2. All hardware components including the roller are warranted not to bend or break under normal use (excluding high winds, water pooling and accidents).

Making a Warranty Claim

If a defect covered by this Warranty appears, the Customer must first contact Aussie Traveller within 7 days of first becoming aware of the defect. Aussie Traveller will assist the Customer to rectify and resolve any Product issue that may arise.

When making a claim under this Warranty, Aussie Traveller requires that the following information be provided before any further action will be taken.

1. Original Invoice (Document or Number);
2. Make and model of the Product;
3. Make and model of the vehicle (if Product fitted);
4. ehicle build date (if Product fitted);
5. Vehicle chassis number;

6. Description of damage and/or repair required;
7. Photos of the damage and/or repair; and
8. Appropriate documentation (such as historical and maintenance records).

Aussie Traveller reserves the right to request more information or images should what is provided not be sufficient to make an assessment for the Warranty claim.

The Product must be made available to Aussie Traveller or its authorised repair agent for inspection and testing. If such inspection and testing find no defect in the Product, the final retail customer must pay Aussie Traveller's usual costs of service work and testing.

The final retail customer must bear the cost of the transport of the Product to and from Aussie Traveller or the authorised repair agent, and all insurance of the Product.

Exclusions

This Warranty will not apply where:

- the Product has been repaired, altered or modified by someone other than Aussie Traveller, or without the written consent of Aussie Traveller or an authorised repair agent;
- the alleged defect in the Product is within acceptable industry tolerances and variances;
- Aussie Traveller cannot establish any fault in the Product after testing and inspection;
- the Product has been used other than for the purpose for which it was designed;
- the alleged defect in the Product has arisen due to the final retail customer's failure to properly use and
- maintain the Product in accordance with any of Aussie Traveller's instructions, recommendations and specifications (including applicable maintenance schedules);
- the alleged defect in the Product has arisen due to the final retail customer's request to customise the Product;
- the Product has been subject to abnormal conditions, including environment, temperature, high or excessive wind, water, fire, humidity, pressure, stress or similar;
- the alleged defect has arisen due to abuse, misuse, neglect or accident;
- unauthorised parts or accessories have been used on or in relation to the Product;
- the Product has been overloaded or involved in an accident;
- the alleged damage or defect has been caused by normal wear and tear;
- the alleged damage to fabric has been caused by storm, wind or rain, or stretching of fabric caused by water pooling on fabric;
- breakage or bending of hardware components has been caused by storm, wind or rain, or water pooling on fabric.

Replacement Warranty Item

If, under Warranty, a Product is replaced or repaired by Aussie Traveller or an Aussie Traveller agent, unless provided in writing to indicate otherwise, the replacement Product will carry the **remaining** Warranty terms and conditions, including length of time, of the original purchased Product.

Change of Mind

Aussie Traveller understands that at times, final retail customers may change their mind. Choose carefully as return and credit requests for items purchased by mistake or "change of mind" reasons may not be approved. Aussie Traveller will not accept Product returns under these circumstances unless by written approval by an authorized Aussie Traveller representative. If approved, an administration and restocking fee may apply.

Limitations

Aussie Traveller makes no express warranties or representations other than set out in this Warranty.

The repair or replacement of the Product or part of the Product is the absolute limit of Aussie Traveller's liability under this express Warranty.

Contact

Australia Wide: 1300 663 868

Melbourne Office
 235 Barry Road
 Campbellfield, Melbourne, 3061
 Ph: +61 3 9357 6565
 enquiries@aussietraveller.com.au

Brisbane Head Office, Factory & Showroom
 11-15 Oasis Court
 Clontarf, Brisbane, 4019
 Ph: +61 7 3284 3284
 enquiries@aussietraveller.com.au

To receive a copy of the Aussie Traveller Warranty Terms & Conditions or information regarding specific Aussie Traveller products, please contact Aussie Traveller Head Office on (07) 3284 3284 or email enquiries@aussietraveller.com.au.